

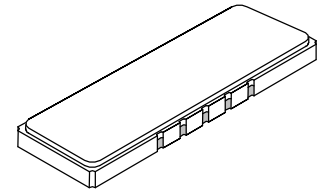



# SF1092A

## 199 MHz SAW Filter



SMP-75

- **Designed for GSM BTS Receiver IF Applications**
- **Low Insertion Loss**
- **Excellent Size-to-Performance Ratio**
- **Hermetic SMP-75 Surface-Mount Case**
- **Unbalanced Input and Output**
- **Complies with Directive 2002/95/EC (RoHS)** 

### Absolute Maximum Ratings

| Rating  | Value          | Units |
|---|----------------|-------|
| Maximum Incident Power in Passband                        | +18            | dBm   |
| Max. DC voltage between any 2 terminals                   | 30             | VDC   |
| Storage Temperature Range                                 | -40 to +85     | °C    |
| Suitable for lead-free soldering - Max. Soldering Profile | 260°C for 30 s |       |

### Electrical Characteristics

| Characteristic                    | Sym   | Notes   | Min     | Typ       | Max       | Units               |
|-----------------------------------|---|---------|---------|-----------|-----------|---------------------|
| Nominal Center Frequency          | $f_C$   | 1       | 199.000 |           |           | MHz                 |
| Passband                          | Insertion Loss at $f_C$<br>1 dB Passband  | IL      |         | 5.5       | 7.0       | dB                  |
|                                   |   | $BW_1$  | 1, 2    | $\pm 100$ | $\pm 140$ | kHz                 |
|                                   | Amplitude Ripple over $f_C \pm 100$ kHz   |         |         |           | 1.0       | dB <sub>p-p</sub>   |
|                                   | Group Delay Variation over $f_C \pm 100$ kHz  | GDV     |         |           | 300       | ns <sub>p-p</sub>   |
| Rejection                         | $f_C - 800$ to $f_C - 600$ and $f_C + 600$ to $f_C + 800$ kHz<br>119 MHz to $f_C - 800$ kHz<br>$f_C + 800$ kHz to 278 MHz | 1, 2, 3 | 35      |           |           | dB                  |
|                                   |   |         | 45      |           |           |                     |
|                                   |   |         | 45      |           |           |                     |
| Operating Temperature Range       | $T_A$   | 1       | -10     |           | +85       | °C                  |
| Frequency Temperature Coefficient | FTC   | 1       |         | 0.32      |           | ppm/°C <sup>2</sup> |

|  |                                      |
|--|--------------------------------------|
| Impedance Matching to 50 $\Omega$ unbalanced | External L-C                         |
| Case Style                                   | SMP-75 19 x 6.5 mm Nominal Footprint |
| Lid Symbolization (YY = year, WW = week)     | RFM SF1092A YYWW                     |

### Notes:

1. Unless noted otherwise, all specifications apply over the operating temperature range with filter soldered to the specified demonstration board with impedance matching to 50  $\Omega$  and measured with 50  $\Omega$  network analyzer.
2. Unless noted otherwise, all frequency specifications are referenced to the nominal center frequency,  $f_C$ .
3. Rejection is measured as attenuation below the minimum IL point in the passband. Rejection in final user application is dependent on PCB layout and external impedance matching design. See Application Note No. 42 for details.
4. The turnover temperature,  $T_O$ , is the temperature of maximum (or turnover) frequency,  $f_O$ . The nominal frequency at any case temperature,  $T_C$ , may be calculated from:  $f = f_O [1 - FTC(T_O - T_C)^2]$ .
5. The design, manufacturing process, and specifications of this filter are subject to change.
6. Either Port 1 or Port 2 may be used for either input or output in the design. However, impedances and impedance matching may vary between Port 1 and Port 2, so that the filter must always be installed in one direction per the circuit design.
7. US and international patents may apply.
8. Electrostatic Sensitive Device. Observe precautions for handling. 

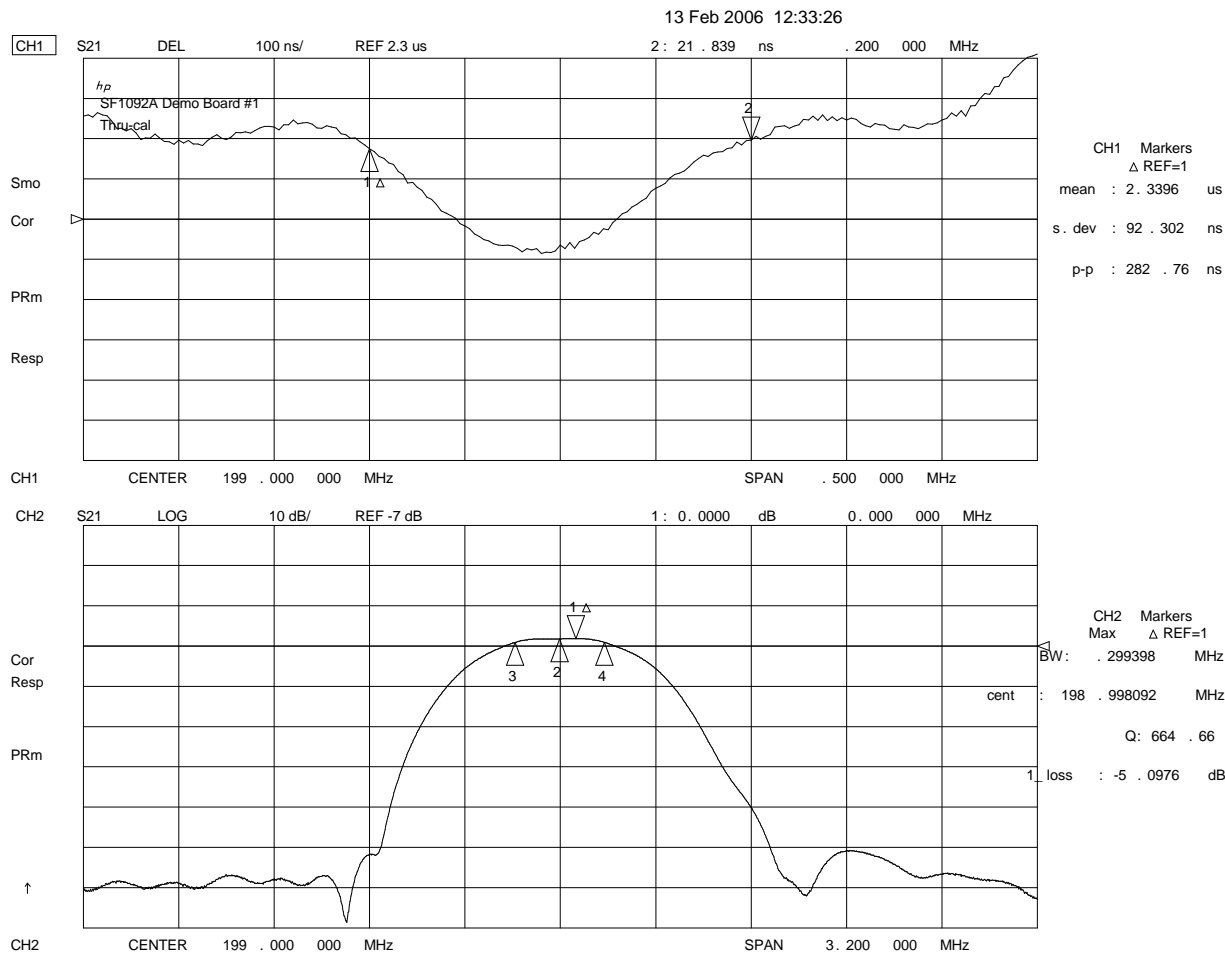
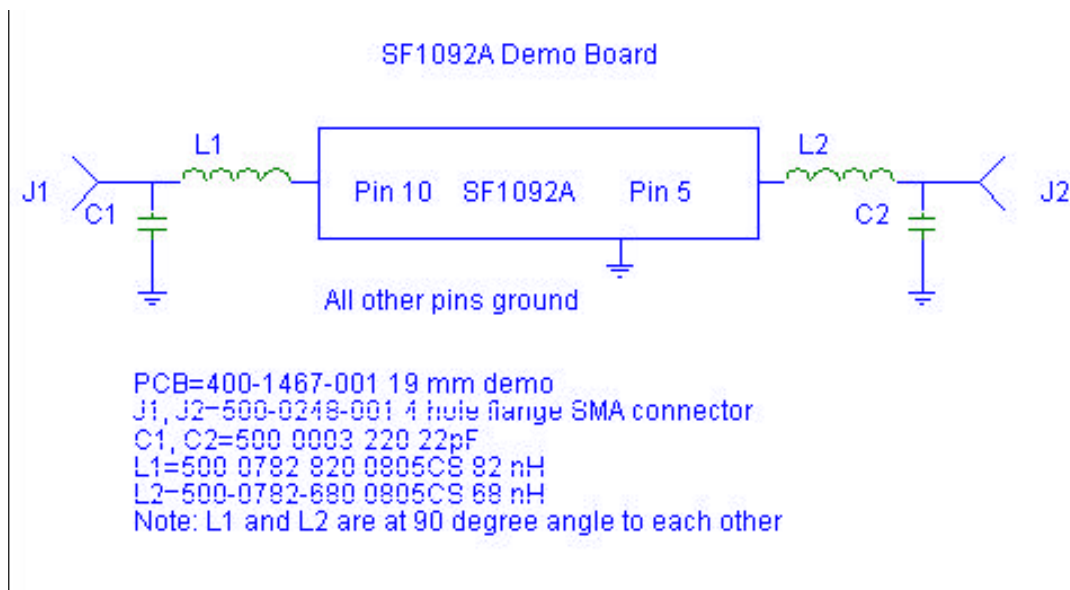

13 Feb 2006 12:34:35

CH1 S11 1 UFS 1: 27.100 Ω 26.697 Ω 21.352 nH 199.000 000 MHz

*hp*  
SF1092A Demo Board #1  
Full 2-port cal

Cor

PRm

Full

↑

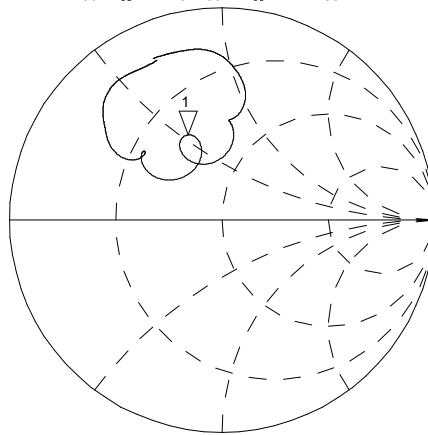

CH2 S22 1 UFS 1: 36.609 Ω 31.684 Ω 25.340 nH 199.000 000 MHz

Cor

Full

PRm

↑

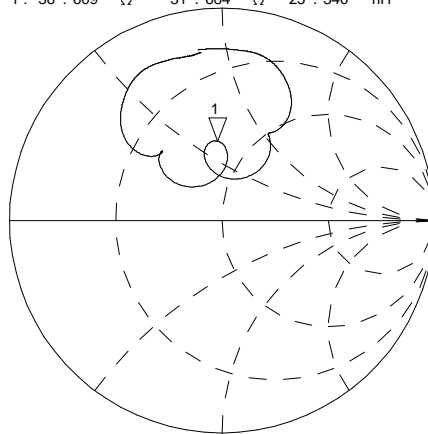

CENTER 199.000 000 MHz

SPAN 3.200 000 MHz

SMP-75 Case

10-Terminal Ceramic Surface-Mount Case  
19 x 6.5 mm Nominal Footprint

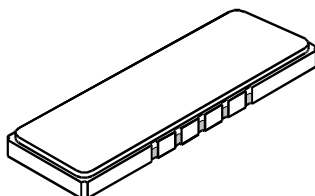

| Case Dimensions |       |       |       |        |       |       |
|-----------------|-------|-------|-------|--------|-------|-------|
| Dimension       | mm    |       |       | Inches |       |       |
|                 | Min   | Nom   | Max   | Min    | Nom   | Max   |
| A               | 18.80 | 19.00 | 19.30 | 0.740  | 0.748 | 0.760 |
| B               | 6.30  | 6.50  | 6.80  | 0.248  | 0.256 | 0.268 |
| C               |       | 1.75  | 2.00  |        | 0.069 | 0.079 |
| D               |       | 2.29  |       |        | 0.090 |       |
| E               |       | 1.02  |       |        | 0.040 |       |
| H               |       | 1.0   |       |        | 0.039 |       |
| P               |       | 1.905 |       |        | 0.075 |       |

| Materials              |  |
|------------------------|--|
| Solder Pad Termination | Au plating 30 - 60 μinches (76.2-152 μm) over 80-200 μinches (203-508 μm) Ni.    |
| Lid                    | Fe-Ni-Co Alloy Electroless Nickel Plate (8-11% Phosphorus) 100-200 μinches Thick |
| Body                   | Al <sub>2</sub> O <sub>3</sub> Ceramic   |
| Pb Free                |  |

| Electrical Connections |                  |                  |
|------------------------|------------------|------------------|
| Connection             |                  | Terminals        |
| Port 1                 | Input or Return  | 10               |
|                        | Return or Input  | 1                |
| Port 2                 | Output or Return | 5                |
|                        | Return or Output | 6                |
| Ground                 |                  | All others       |
| Single Ended Operation |                  | Return is ground |
| Differential Operation |                  | Return is hot    |

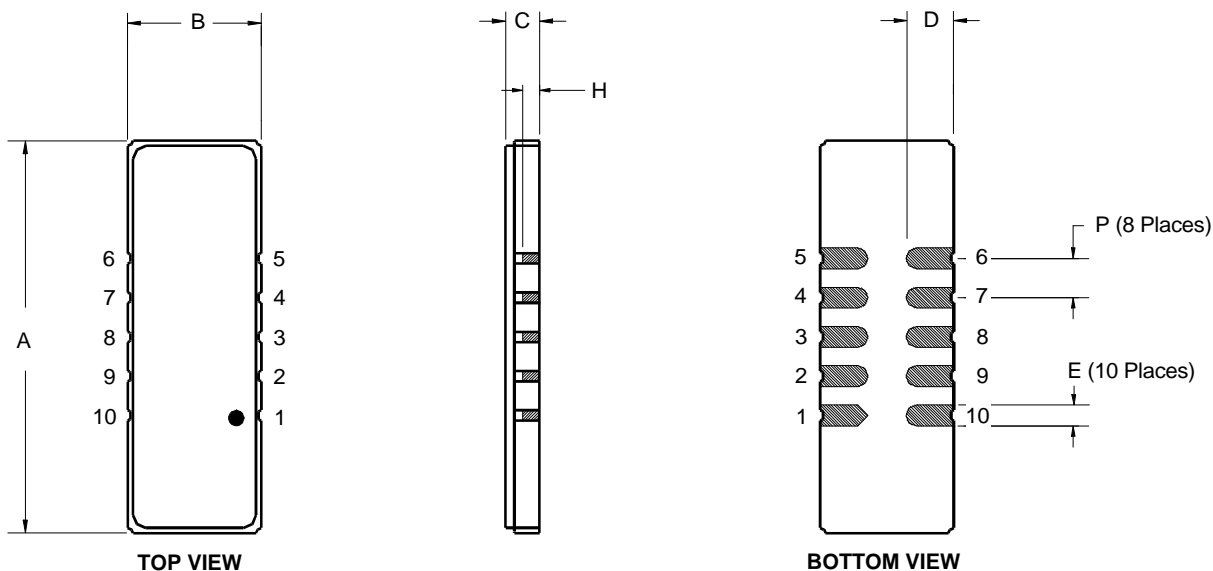

COMPONENT ORIENTATION and DIMENSIONS

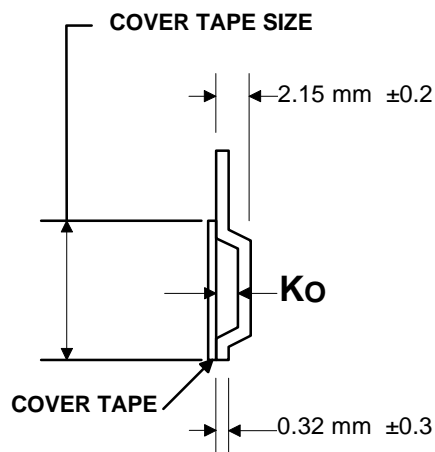
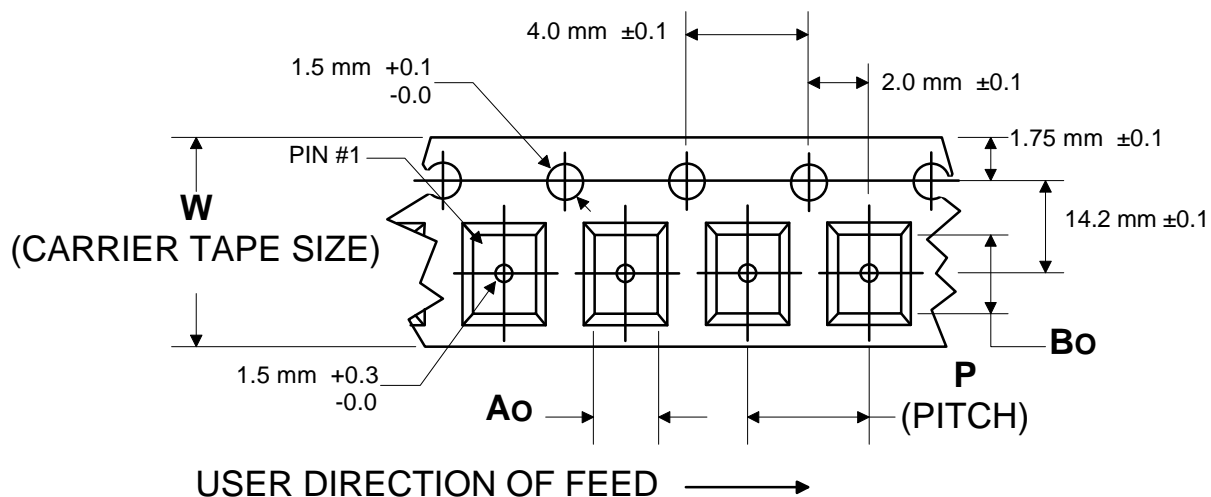

| Carrier Tape Dimensions |          |      |
|-------------------------|----------|------|
| <b>Ao</b>               | 7.2 mm   | ±0.1 |
| <b>Bo</b>               | 19.51 mm | ±0.1 |
| <b>Ko</b>               | 2.24 mm  | ±0.1 |
| <b>Pitch</b>            | 12.0 mm  | ±0.1 |
| <b>W</b>                | 32.0 mm  | ±0.3 |