

ESD Protection

By: Lee A. Mrha

RFM's low cost 'RX' receivers and 'HX' transmitters use SAW (surface acoustic wave) devices as an important part of the circuitry. For example, SAW coupled resonator filters (CRF's) are used for front end filtering of the receiver's front end. CRF's are also used for harmonic suppression of the 'HX' transmitters. The use of SAW devices has greatly simplified receive and transmit functions making "ready to use" RF modules available for a multitude of applications.

Even though these modules have made implementing RF low power receive and transmit functions much easier to use, ESD protection is still necessary. CRF's will tolerate ESD on the order of 200 volts (See HX/RX Designer's Guide). A simple inductor to ground at the antenna port (see Figure 1) will normally provide adequate protection of a SAW device. The inductor shorts most of the ESD voltage to ground. This will also provide ESD protection to the bipolar transistors that may be used as part of a transmit/receive switch such as those used in RFM's data radio boards. A typical inductor value of 100 nH works well at 916.5 MHz. At 433.92 MHz a 180 nH inductor to ground works well. For other frequencies, select an inductor value with an RF impedance of 300 to 500 ohms.

In our DR1007 data radio board we use a MMIC amplifier (NEC UPC2647TB) in front of the receiver to increase sensitivity at 916.5 MHz. The NEC MMIC amplifier is ESD sensitive and will begin to degrade with as little as 50 volts of ESD. Due to the fast rise and fall times of an ESD pulse, a simple inductor to ground doesn't reduce an ESD voltage to zero. Even a small ESD voltage at the input of the MMIC amplifier may not completely destroy it, but will begin to damage the MMIC amplifier causing a decrease in amplifier gain. The input impedance of the MMIC amplifier is typically 50 ohms. The problem is to provide adequate ESD protection for the MMIC amplifier at the low input impedance.

Here is a solution to the problem that works very well. Two BAV99 hot carrier diodes (see Figure 2) are connected from the antenna port to ground. The BAV99 hot carrier diodes can be obtained from Philips or Zetex. The BAV99 is packaged as two hot carrier diodes in a SOT-23 package and is ideal for this circuit arrangement. The only problem is that each diode has 1.5 pF of capacitance for a total of 3 pF of capacitance in this configuration. At 916.5 MHz we connected a 10 nH inductor in parallel with the diodes to resonate out the combined capacitance of the two diodes. The inductor not only resonates with the capacitance of the diodes, but also sinks a large portion of any ESD to ground. Any residual ESD voltage not conducted to ground by the 10 nH inductor is easily conducted to ground by one of the diodes. Using this arrangement, we were able to withstand an electrostatic discharge of 8 kV ten times in a row at the antenna port with no degradation to the MMIC amplifier. This same arrangement can be used at other frequencies by calculating the inductance necessary to resonate with the 3 pF of capacitance.

To calculate the inductance, use the well known formula: $L = 1 / C * (2 \Pi F)^2$ where L = henries, C = farads, and F = hertz.

Using the BAV99 diodes with the inductor to ground provides optimum protection for devices that are very sensitive to ESD. This combination provides better ESD protection than using a single inductor.

It is possible to purchase other small surface mount ESD protection devices. The typical trigger voltage of such components is 60 volts to 100 volts with a typical capacitance of less than 1 pF. Results at RFM demonstrate that optimum protection for ESD sensitive devices is best obtained with the BAV99 diodes in combination with an inductor to ground to resonate out the capacitance of the diodes.

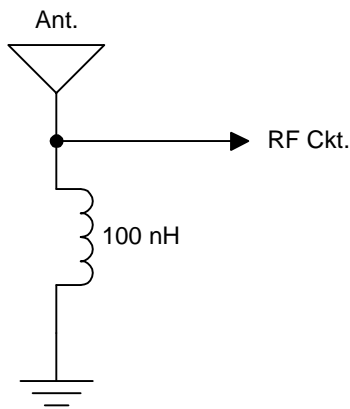

Figure 1

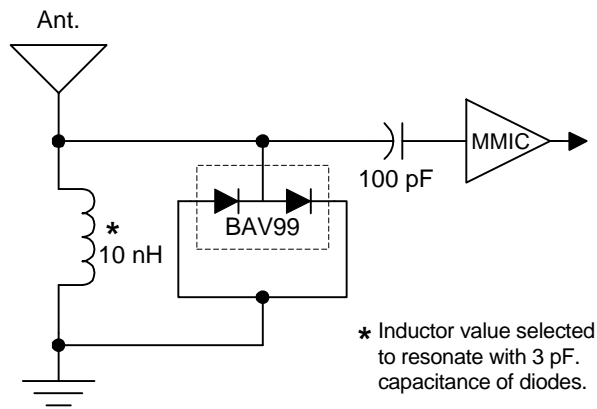

Figure 2

* Inductor value selected to resonate with 3 pF. capacitance of diodes.