

APPLICATION NOTE

**UAA3220TS with SAW-stabilized
local oscillator**

AN99044

Abstract

This report describes the application of the integrated circuit UAA3220TS with a surface acoustic wave (SAW) resonator based local oscillator. The necessary changes are presented to adapt the application circuits as given in the data sheet ([1]) and the application note AN98104 ([2]).

© Philips Electronics N.V. 1999

All rights are reserved. Reproduction in whole or in part is prohibited without the prior written consent of the copyright owner. The information presented in this document does not form part of any quotation or contract, is believed to be accurate and reliable and may be changed without notice. No liability will be accepted by the publisher for any consequence of its use. Publication thereof does not convey nor imply any license under patent- or other industrial or intellectual property rights.

APPLICATION NOTE

UAA3220TS with SAW-stabilized local oscillator

AN99044

Author(s):

Stephan de Zeeuw
Philips Semiconductors Systems Laboratory Hamburg,
Germany

Keywords

superheterodyne architecture
UHF/VHF single-chip receiver
remote control
Amplitude Shift Keying (ASK) receiver
Frequency Shift Keying (FSK) receiver
Surface Acoustic Wave (SAW) resonator

Number of pages: 15

Date: 99-08-31

Summary

The integrated circuit UAA3220TS has been intended to operate with a local oscillator based on a crystal oscillator and frequency multiplication. This report describes the application of the UAA3220TS with a surface acoustic wave (SAW) resonator based local oscillator. The necessary changes are presented to adapt the application circuits as given in [1] and [2].

The first section gives an overall view of the advantages of a SAW-based local oscillator with respect to the original application. Section 2 describes the necessary hardware changes in general. Section 3 focuses on hints for PCB layout design to achieve optimum receiver performance. Receiver schematics for a receive frequency of 433.92 and 868.35 MHz respectively are given in section 4 together with the corresponding PCB layout. Section 5 presents measurement results.

Please note that all figures and measurement results presented in this paper are typical values only and may vary as a result of device spreads, component tolerances or temperature changes. For a detailed description of the IC characteristic please refer to [1]. Detailed application support is given in [2].

CONTENTS

1.	INTRODUCTION	7
2.	GENERAL DESCRIPTION	8
2.1	Local oscillator with external transistor	8
2.2	Local oscillator using internal transistors	9
2.3	Multiplier	9
3.	PCB LAYOUT GUIDELINES	10
4.	APPLICATION EXAMPLES	10
5.	TYPICAL ELECTRICAL CHARACTERISTICS	14
6.	ACKNOWLEDGEMENT	15
7.	LIST OF MANUFACTURERS	15
8.	REFERENCES	15

1. INTRODUCTION

The UAA3220TS is a fully integrated single chip VHF/UHF receiver based on the superheterodyne architecture. The received high frequency carrier (e.g. 315, 433.92 or 868.35 MHz) is down-converted to the intermediate frequency (IF) of typical 10.7 MHz by means of the local oscillator (LO) signal. The UAA3220TS has been designed to employ a local oscillator consisting of a crystal resonator stabilized oscillator and frequency multiplication (see [2]). To achieve optimum receiver performance in terms of sensitivity and spurious rejection it is mandatory to provide

- a high crystal frequency and
- tuning capacitors.

Alignment of the employed tank circuits can be avoided when components with fixed values and tight tolerances (smaller than 5%) are used, thus degrading system performance.

This report describes the generation of the local oscillator signal by means of a SAW resonator based local oscillator. The usage of SAW resonators offers some significant advantages:

- SAW resonators are available for most ISM frequencies from several manufacturers (e.g. see chapter 7).
- A SAW resonator stabilized oscillator generates the high frequency LO signal directly. Since the high quality SAW resonator determines the oscillator frequency, there is no need for tuning. Furthermore, generated harmonic frequencies are far spaced from the wanted LO signal and spurious radiation as well as spurious rejection are less problematic.
- A local oscillator based on SAW resonator offers a very good phase noise characteristic and consumes little current.

On the other hand special attention has to be paid to the IF bandwidth: The system (transmitter and receiver) has to be designed properly so that the overall IF frequency drift fits to the bandwidths of commonly available ceramic 10.7 MHz filters.

The input of the UAA3220TS offers an almost flat frequency characteristic; a receiver with a simple input matching network results in poor input selectivity and reverse isolation respectively. The overall receiver design can be completed and optimised using an additional SAW front-end filter: Spurious radiation, selectivity and blocking performance are increased significantly.

Due to several references made in this report, we recommend to have the application note AN98104 (see [2]) available.

2. GENERAL DESCRIPTION

The application of the UAA3220TS using a SAW resonator stabilized local oscillator takes advantage of the on-chip building blocks. The differences to the application circuits as given in [1] and [2] are described in the following.

2.1 Local oscillator with external transistor

The on-chip oscillator transistor of the UAA3220TS is internally coupled to the frequency multiplier with an 8.2 pF capacitor (see [2]). Especially at higher frequencies, e.g. at 857.65 MHz, this capacitor only offers a very low impedance to the local oscillator. For this reason, the internal oscillator transistors are not used for this frequency range and a complete external local oscillator is employed (see Figure 1). Pin 2 (OSE) and pin 3 (OSB) are not connected.

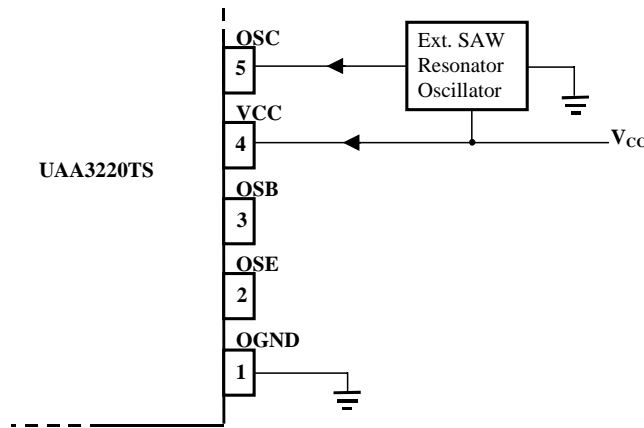

Figure 1: Application of the UAA3220TS with external SAW resonator oscillator

A Colpitts oscillator is used to build up the external local oscillator (see Figure 2). The transistor BFT25A (Philips) has been chosen as oscillator transistor as it enables oscillation at low supply voltages (down to 2.7V) and offers almost constant high output impedance over the complete supply voltage range. With the SAW-device connected to ground, the transistor operates in common-base configuration.

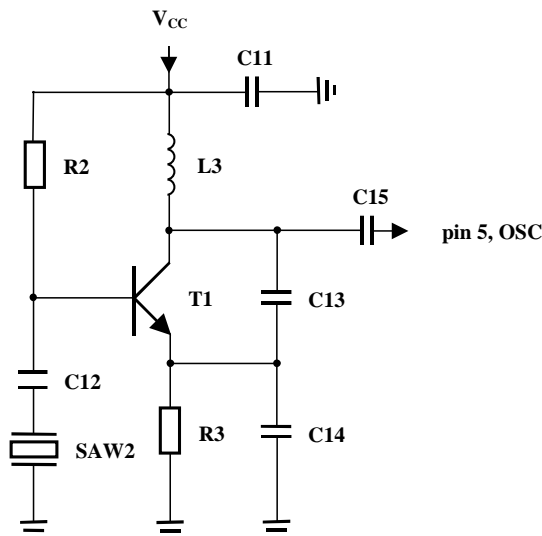

Figure 2: SAW based local oscillator configuration with external transistor

The SAW resonators are one-port devices and are bi-directional. They offer 0-degree phase shift and low resistive impedance at resonance frequency. C12 is used to de-couple the SAW resonator from DC which offers a better temperature characteristic of the overall oscillator.

The resonant load of the transistor consists of the inductance L3 in parallel to the capacitors C13 and C14, which provide the oscillator feedback. At resonance the inherent series resistance of the inductance is transformed to a high value and presented to the collector of the transistor. R2 and R3 set the transistor biasing. Furthermore R3 allows to control the transistor collector current and thus the LO output signal level. Its value has to be chosen so that the specified mixer conversion gain is reached (see [1]). The local oscillator signal is fed to the multiplier section via capacitor C15 to pin 5 (OSC). C11 bypasses the supply voltage to ground at the LO frequency.

Special attention has to be paid to the IF bandwidth. The overall intermediate frequency deviation from the nominal value (resonator centre frequency tolerances, component tolerances and temperature drift on the receiver as well as on the transmitter side) has to be adapted to the ceramic 10.7 MHz filters (larger IF bandwidths are available in SMD style also, see chapter 7). The necessary IF bandwidth can be lowered using either tighter tolerated components and reducing the overall temperature coefficient of the local oscillator circuit.

2.2 Local oscillator using internal transistors

For lower local oscillator frequencies (e.g. 423.22 MHz and less) the internal 8.2 pF coupling capacitor offers higher impedance compared to 857.65 MHz. In this case the LO can be designed based upon the internal oscillator transistors (see Figure 3) using the same oscillator configuration as described in chapter 2.1. Please note, that the current through resistor R3 shall not exceed about 1 mA permanently.

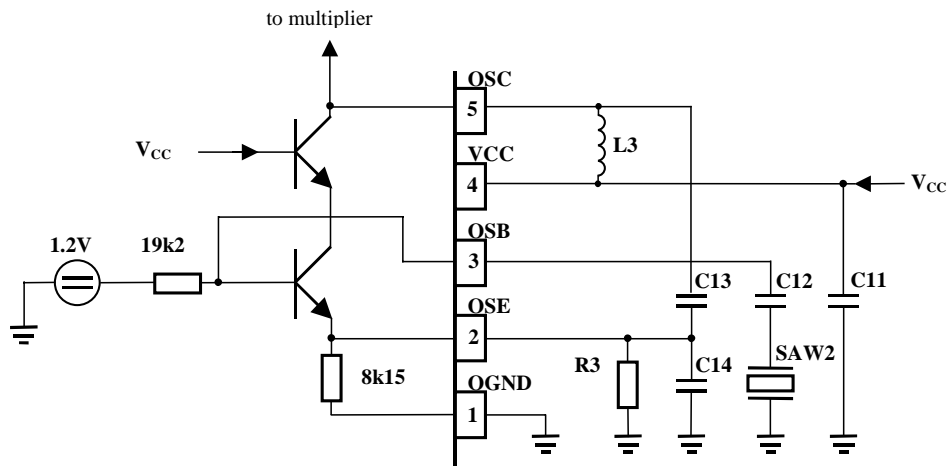

Figure 3: SAW based local oscillator using internal transistors of the UAA3220TS

2.3 Multiplier

The local oscillator generates an unbalanced signal, which is converted to a symmetric drive for the mixer by the multiplier section.

Unwanted frequencies (e.g. harmonics of the LO frequency) are generated also, which are present at the multiplier input, too. Furthermore, the multiplier generates an almost square shaped voltage which contains all odd harmonics of the LO drive signal. In order to prevent these unwanted frequencies of being present at the mixer input, it is necessary to employ a parallel resonant circuit at pin 7 (TN) and pin 8 (TP) further. This circuit is tuned to resonance at the LO frequency. In contrast to the application described in [2], a fixed capacitor value for C18 is sufficient.

3. PCB LAYOUT GUIDELINES

Beyond the hints given in [2], the following recommendations should be considered for a proper layout design:

For the given application, the design should be started with the layout of the local oscillator section, as this area is most important regarding spurious radiation and receiver sensitivity:

The Colpitts oscillator comprising the SAW resonator, the transistor, the capacitors C13 and C14 and the inductance L3 respectively draw a large RF current from the supply line. In order to minimise the RF current path –and thus spurious radiation from the LO-, the capacitor C11 bypasses the supply line to ground. Hence, the ground points of the SAW resonator, the capacitors C11 and C14 should be placed physically close together. The ground points of these components should be connected to a solid ground plane below the oscillator section at least with two vias each.

The requirement to minimise all RF paths brings about to place all components of the LO as close together as possible. Please note, that every millimetre of additional PCB line between the components adds about 1 nH inductance and thus acts as an additional source of radiation. The above described design goals can be reached easily using SMD capacitors and inductances of style 0603.

Finally, a solid ground plane should be provided below and around the local oscillator. This measure further minimises spurious radiation and coupling to the receiver front-end section respectively. Furthermore, stable oscillation conditions are provided.

The design should be continued with the multiplier section; detailed application support is given in the application note (see [2]).

Special PCB layout design hints for the SAW front-end filter can be found in several application notes from SAW device manufacturers (see also chapter 7).

4. APPLICATION EXAMPLES

Figure 4 and Figure 5 give application examples for two carrier frequencies (433.92 MHz and 868.35 MHz) at a data rate of 1 kbps. These examples allow the use of either ASK or FSK demodulation.

For FSK mode (with a frequency deviation of 10 kHz), jumper J1 has to be removed. Both boards offer the possibility to employ either a discrete parallel resonant circuit at pin 10 (DEMO1) and pin 11 (DEMO2) or an SMD style ceramic discriminator (see chapter 7, available for a temperature range from -10° to $+50^{\circ}\text{C}$ only).

Please note, that the given component values have been adapted to the board layout (see Figure 6). Other PCB designs may require different component values.

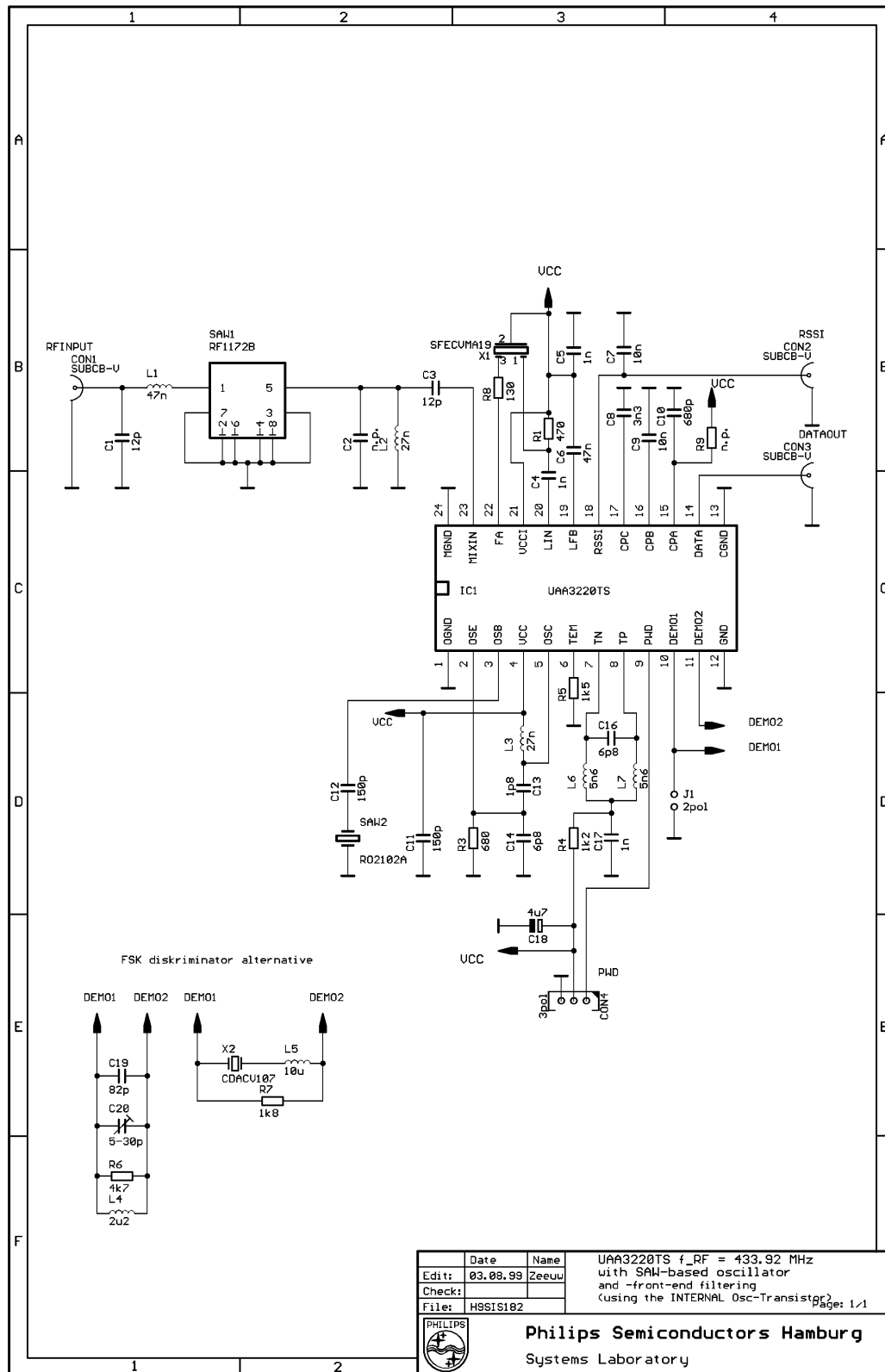

Figure 4: Typical application for $f_{RF} = 433.92$ MHz, $f_{Data} = 1$ kbps (FSK mode: $\Delta f = 10$ kHz, J1 removed)

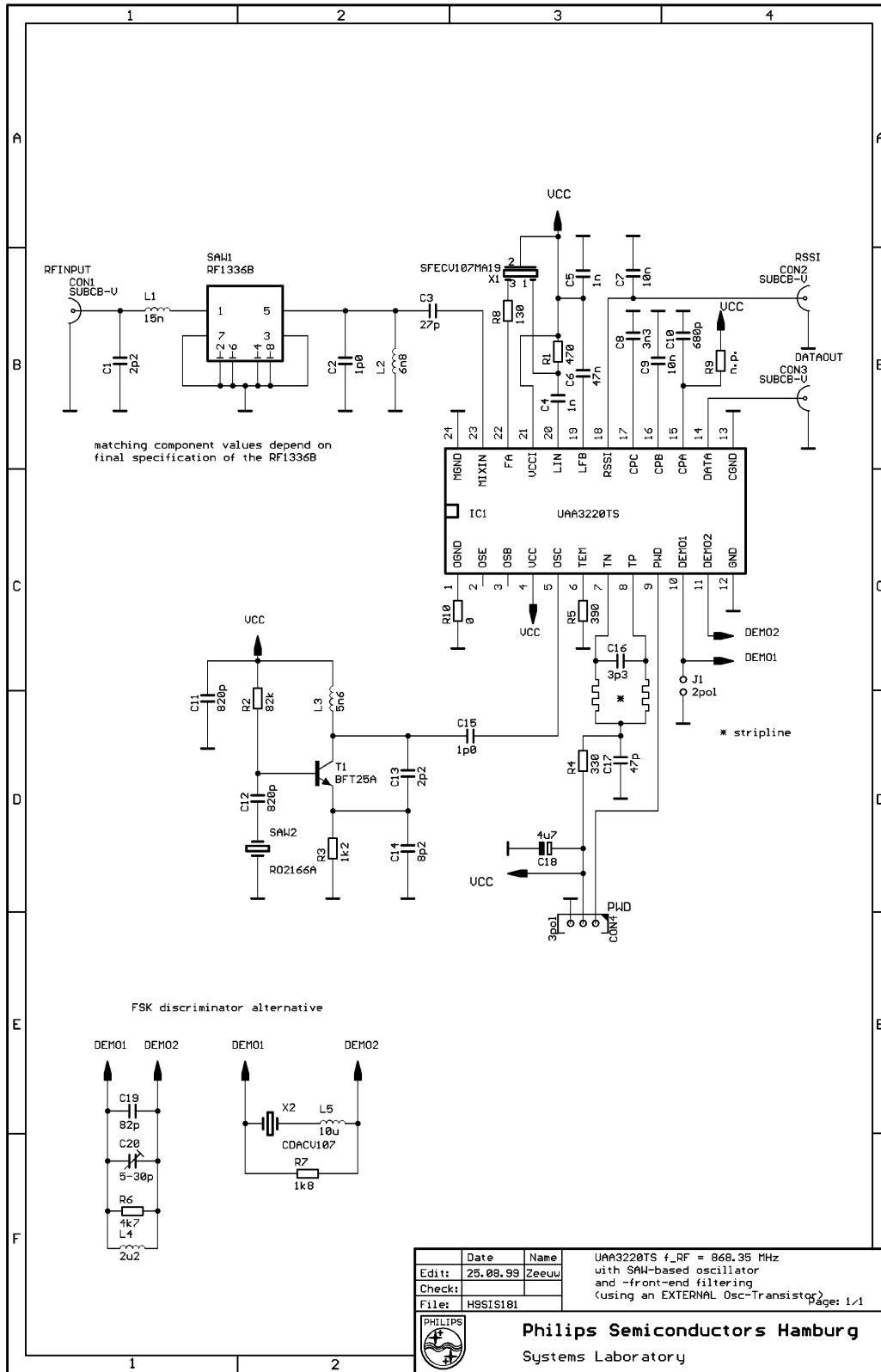

Figure 5: Typical application for $f_{RF} = 868.35$ MHz, $f_{Data} = 1$ kbps (FSK mode: $\Delta f = 10$ kHz, J1 removed)

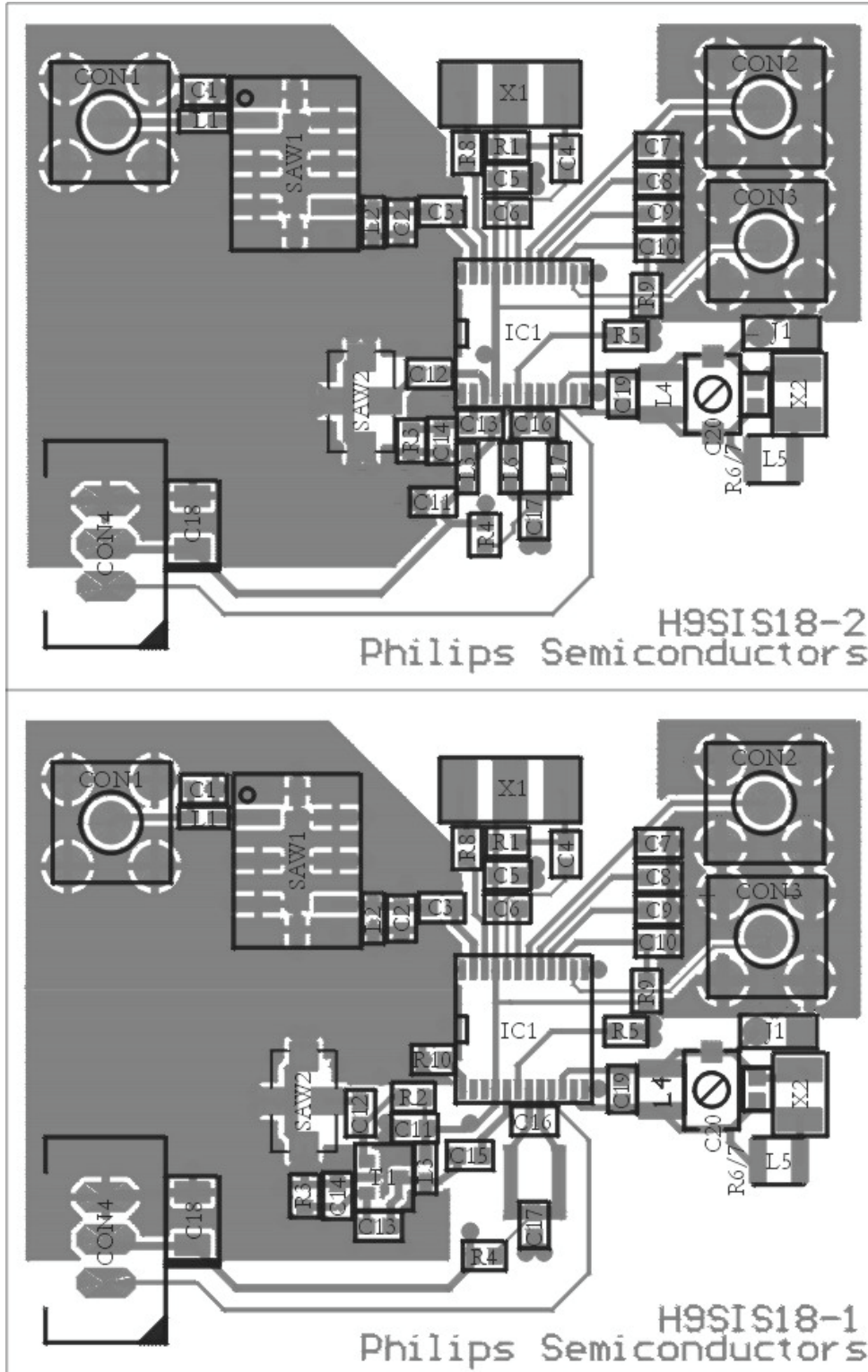

Figure 6: H9SIS18-1/2 layout and component placement, top side

5. TYPICAL ELECTRICAL CHARACTERISTICS

Measurement conditions:

- $V_{CC} = 2.7\text{ V}$, $T_{amb} = 22^\circ\text{C}$
- ASK modulation, $f_{Data} = 1\text{ kbps}$ (square shaped, duty cycle 50%)
- Spurious radiation measured at the RF-input connector
- The LeCroy LC584AXL oscilloscope -including the “Jitter and Timing Analysis (JTA)” software option- has been used to measure the sensitivity. The sensitivity limit was defined as follows: 99,9% of the data output signal had to have a duty cycle deviation of smaller than 5%.

$f_{RF} [MHz]$	$P_{Sens, ASK} [dBm]$	$P_{spur1, LO} [dBm]$	$P_{spur2, LO} [dBm]$	$I_{CC} [mA]$
433.92 (H9SIS18-2)	-106	< -78	< -85	3,9
868.35 (H9SIS18-1)	-106	< -80	< -90	4,9

Figure 7 gives the phase noise of the local oscillator measured under the following conditions:

- $V_{CC} = 2.7\text{ V}$, $T_{amb} = 22^\circ\text{C}$
- Test frequency = 857.65 MHz
- The connection between the local oscillator and the UAA3220TS has been opened at pin 5 (OSC). The local oscillator has driven the spectrum analyser (HP8568B) directly; special test software has been used to complete the measurement.

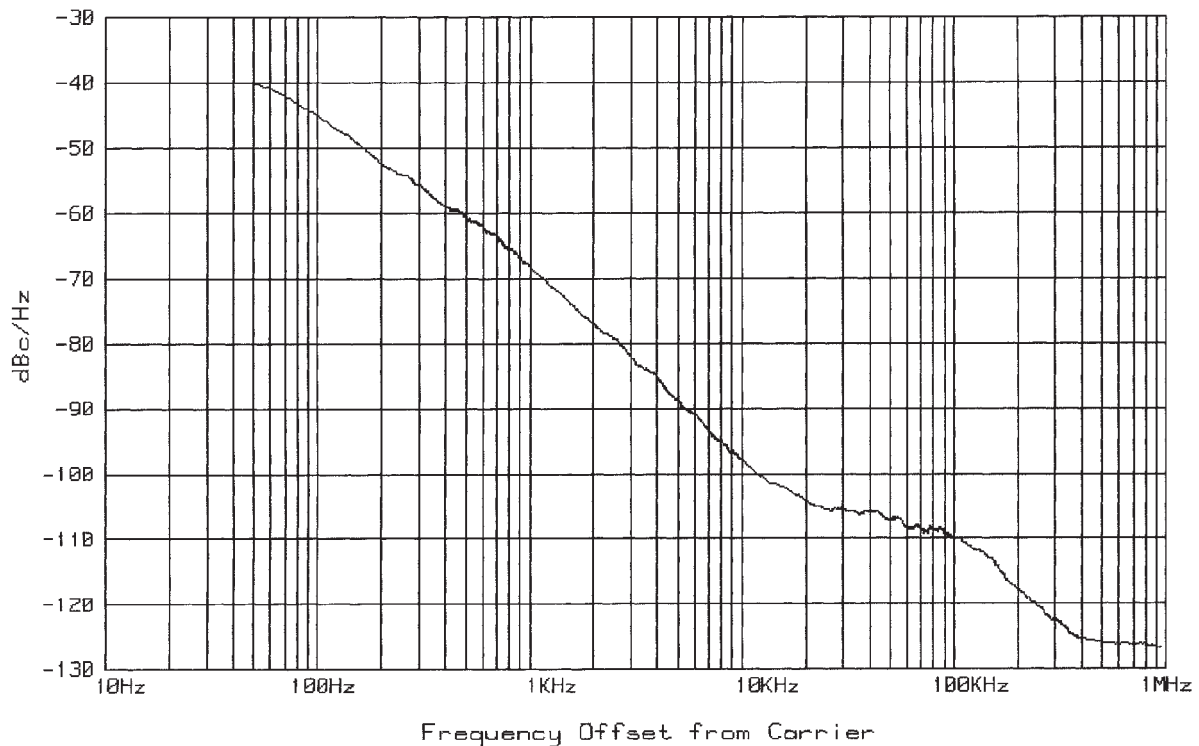

Figure 7: Measured phase noise performance at 857.65 MHz

6. ACKNOWLEDGEMENT

This application has been developed with the kindly support of the

Application Laboratory Vogels
Mr. Paul Vogels
Dickhofskamp 26
44227 Dortmund
Germany
Phone/Fax: ++49 231 753324

7. LIST OF MANUFACTURERS

The following list gives an overview over selected components and their manufacturers used for the described application circuits. The given internet addresses offer links to specifications, application notes and the corresponding sales representatives/distributors.

Manufacturer	selected components
Murata Manufacturing Co., Ltd 26 10, Tenjin 2-chome, Nagaokakyo-shi Kyoto 617-8555, Japan Phone (075) 951-9111 http://www.ijinet.or.jp/murata/index.html	ceramic filters and discriminators: SFECV 10.7MS3A10, SFECV10.7MA2, SFECV10.7MA19.... chip coils: Series LQP11A and LQG11A
RF Monolithics, Inc. 4347 Sigma Road Dallas, Texas 75244-4589, USA Phone: (800) 704-6079 Phone: (972) 448-3700 Fax: (972) 387-8148 http://www.rfm.com	SAW resonators: RO2102A, RO2125A, RO2166A SAW filters: RF1211B, RF1172B, RF1336B

8. REFERENCES

- [1] Data Sheet UAA3220TS, Frequency Shift Keying (FSK)/Amplitude Shift Keying (ASK) receiver; 1998 Nov 26
- [2] Application Note UAA3220TS, AN98104; 1998 November 18