

Capabilities and Applications of SAW Coupled-Resonator Filters

by Allan Coon
December, 1990

INTRODUCTION

Although **Surface Acoustic Wave Coupled-Resonator** (SAW CR) filters have been readily available for several years, two issues currently inhibit the effective use of this technology: 1) Rapidly evolving technical performance has resulted in a lack of awareness by the design community of current capabilities, and 2) Systems originally designed for conventional filtering technologies, often *cannot* achieve optimum performance and cost because SAW CR filters were not considered in the initial system design.

Single-pole resonators using SAW cavities were first proposed in 1970. [1, 2] By the mid 1970's, single-pole resonators were becoming practical and multi-pole SAW CR filters were shown to be feasible. [3, 4] In the early 1980's, CR filters of up to six poles were demonstrated [5-7] and two-pole SAW CR filters became readily available in quantity and at reasonable cost. SAW CR filters at frequencies as high as 1500 MHz were demonstrated in the mid 1980's. [8]

In spite of the knowledge of SAW CR filter capabilities in the ultrasonics community and the availability of practical devices in production volumes, this particular technology is still not well known among RF circuit and system designers. A surprisingly large percentage of RF design engineers seem unaware of the capabilities presently available and the design possibilities made viable by this technology.

SAW CR filters possess narrow bandwidths (typically 0.03% to 0.6%), low insertion losses (as low as 2 dB), and good ultimate rejection *without* harmonic spurious responses. Combined with center frequencies up to 1650 MHz, this type of filter is ideal for many consumer, industrial, and military applications in signal selection and frequency control. In addition, SAW CR filters often offer the smallest size and lowest unit cost of any of the alternatives.

In this application note, a brief overview of basic SAW CR filter concepts is followed by a description of current practical performance capabilities important to the RF design engineer. The capabilities of SAW CR filters are then compared with other passive bandpass filter technologies with an emphasis on optimizing the selection process at the system

design level. As a design aid, a reference chart is presented covering practical, passive devices in the frequency range of 10 MHz to 10 GHz. Several application examples of SAW CR filters are also presented.

THE BASIC CONCEPT

Theory of operation is not the subject of this application note. However, a very brief review and description of the basic concepts is in order as a point of reference for the RF design engineer.

In and near the passband, the SAW CR filter may be modeled by the two-pole lumped element equivalent circuit shown in Figure 1. In this model, R_m , L_m , and C_m are the motional resistance, inductance, and capacitance values of each acoustic resonant cavity. C_0 is static capacitance which includes both case parasitic capacitance and capacitance between electrodes. C_{12} represents the acoustic coupling between the two resonant cavities, and as a practical matter, also includes parasitics. (This model is not valid in the reject band, however.) [9]

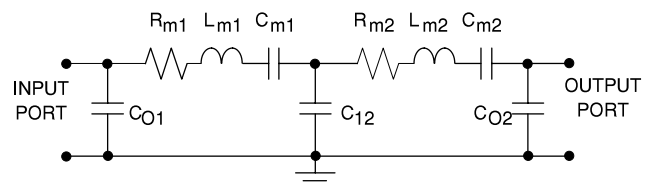

Figure No. 1: 2-Pole LC Equivalent Model

The SAW CR filter relies on the piezoelectric effect. Electric waves are converted into surface acoustic waves at the input of the device by an **Inter-Digital Transducer (IDT)** composed of metal electrodes on, or recessed into, the surface of a substrate material. These acoustic waves excite a half wavelength ($\lambda/2$) resonant acoustic cavity formed between the transducer and a reflective grating, or within the transducer itself. Energy is then coupled to another $\lambda/2$ resonant acoustic cavity and converted back to electric

waves at another IDT at the output. Impedance matching between the IDT's and the external electrical circuit is usually required for lowest insertion loss.

There are three principal methods of coupling the two acoustic cavities. One common method relies on the evanescent acoustic field between two side-by-side cavities. This coupling mode is referred to variously as evanescent coupling, waveguide coupling, transducer coupling, or proximity coupling. The resulting "double-mode" or "multi-mode" CR filters provide good performance in a practical design and are presently manufactured in high volume for pager receiver front-end applications [10, 11]. Coupling may also be directional via a multistrip coupler or the cavities can be in-line (collinear) with the surface wave. Each of these methods offers some advantages. [4] However, in-line coupling results in the simplest and most compact structure, which is desirable for practical volume manufacturability. In-line coupling may be accomplished with a metal grating on the surface or with grooves. A generalized schematic representation of an in-line coupled filter is shown in Figure 2.

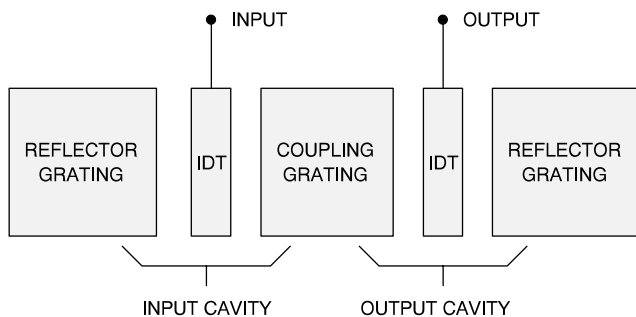

Figure No. 2: Schematic of In-Line SAW CR Filter

Several substrate materials are possible, but quartz is by far the most common because it results in the best temperature characteristic. Also, various metals may be used for the metal electrodes. The most common is aluminum or an alloy of aluminum and copper.

State-of-the-art insertion loss, out-of-band spurious responses, and best symmetry in the frequency domain require minimized reflections internal to the transducers and maximized coupling between transducers and the acoustic standing wave. Traditionally, this has been accomplished with electrodes recessed in grooves or by the use of various "split electrode" arrangements using transducer electrodes narrower than $\lambda/4$. These techniques have resulted in high performance with regard to the parameters mentioned above, but with some significant practical limitations. These limitations include limited practical upper frequencies (about

800 MHz), high manufacturing costs, and various design complications (i. e., the design is not "well behaved"). Consequently, these high-performance designs have only been suitable for high-budget applications. They have never been available in significant production volumes for commercial applications.

Likewise, CR filters with three and more poles, for improved selectivity, have been successfully designed and fabricated. To date, these designs have not gained widespread acceptance due to considerable fabrication difficulties.

Developments in two-pole SAW CR filter technology at RF Monolithics have eliminated the need for either recessed or split electrodes in high-performance SAW CR filters. Internal transducer reflections can be eliminated and acoustic coupling maximized by one of several other methods. One method uses special quartz crystal orientations to achieve a **Natural Single-Phase Unidirectional Transducer (NSPUDT)**. The other employs a "hiccup" acoustic resonant cavity in the transducer. [12-16] Figure 3 shows the configuration of a typical two-pole SAW CR filter with a single "hiccup" cavity. Typically, various weighting functions (not shown here) are designed into the transducers.

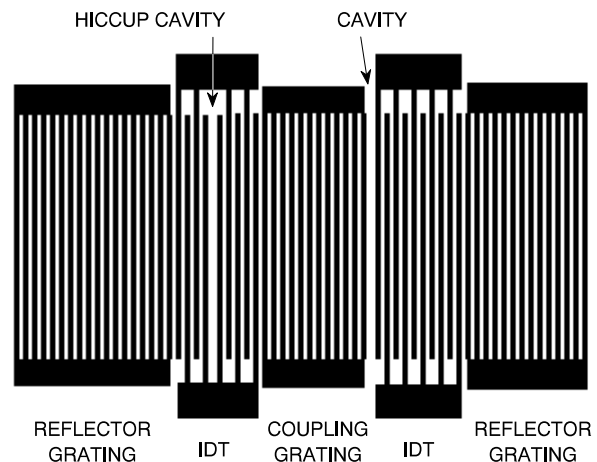

Figure No. 3: SAW CR Configuration with "Hiccup"

One or both IDT's may employ a "hiccup" cavity. A SAW CR filter employing only one "hiccup" has almost symmetrical out-of-band response. CR filters with a "hiccup" in both transducers have exceptionally good rejection below the passband frequency but slightly worse passband flatness and worse high-side rejection. A common variation on this theme is the use of a "hiccup," as shown above, in one transducer and a "conjugate hiccup" cavity in the other transducer. In the "conjugate hiccup" cavity, electrode polarity is reversed on each side of the cavity.

These “hiccup” cavity designs are readily modeled and designed with the aid of Coupling-Of-Modes (COM) theory. [17, 18] Two-pole “hiccup” SAW CR filters are well-behaved and are readily manufacturable in high volumes at low cost. This is the type of practical design discussed in the following sections.

CURRENT PERFORMANCE CAPABILITIES

In this section, we will first consider the performance limitations of the basic parameters, center frequency and bandwidth. The discussion of bandwidth necessarily requires a detailed explanation of practical production tolerances and temperature characteristics. Next, insertion loss and impedance matching are discussed. This is followed by rejection and passband characteristics. Finally, several other performance issues are covered.

The type of SAW CR filter described in the previous section is presently available in center frequencies as high as 1650 MHz. (Note that not all SAW CR filter designs are capable of this high of a center frequency.) Although technically feasible down to frequencies below 30 MHz, the limitations of size and cost set a practical lower limit of about 70 MHz. An optimum mix of small size and lowest manufacturing costs occurs approximately in the frequency range of 200 to 1200 MHz.

The most readily achievable pass bandwidths (3 dB) fall in the range of approximately 0.03% to 0.2%. The upper limit currently feasible is 0.6%. Bandwidths narrower than 0.03% are possible, but are seldom practical due primarily to center frequency manufacturing tolerances and drift with temperature. The region of practical SAW CR filters is plotted on a plane of fractional bandwidth versus center frequency in Figure 4. Note that the highlighted central region illustrates where SAW CR filters are generally superior to any other bandpass filter technology in most applications. SAW CR

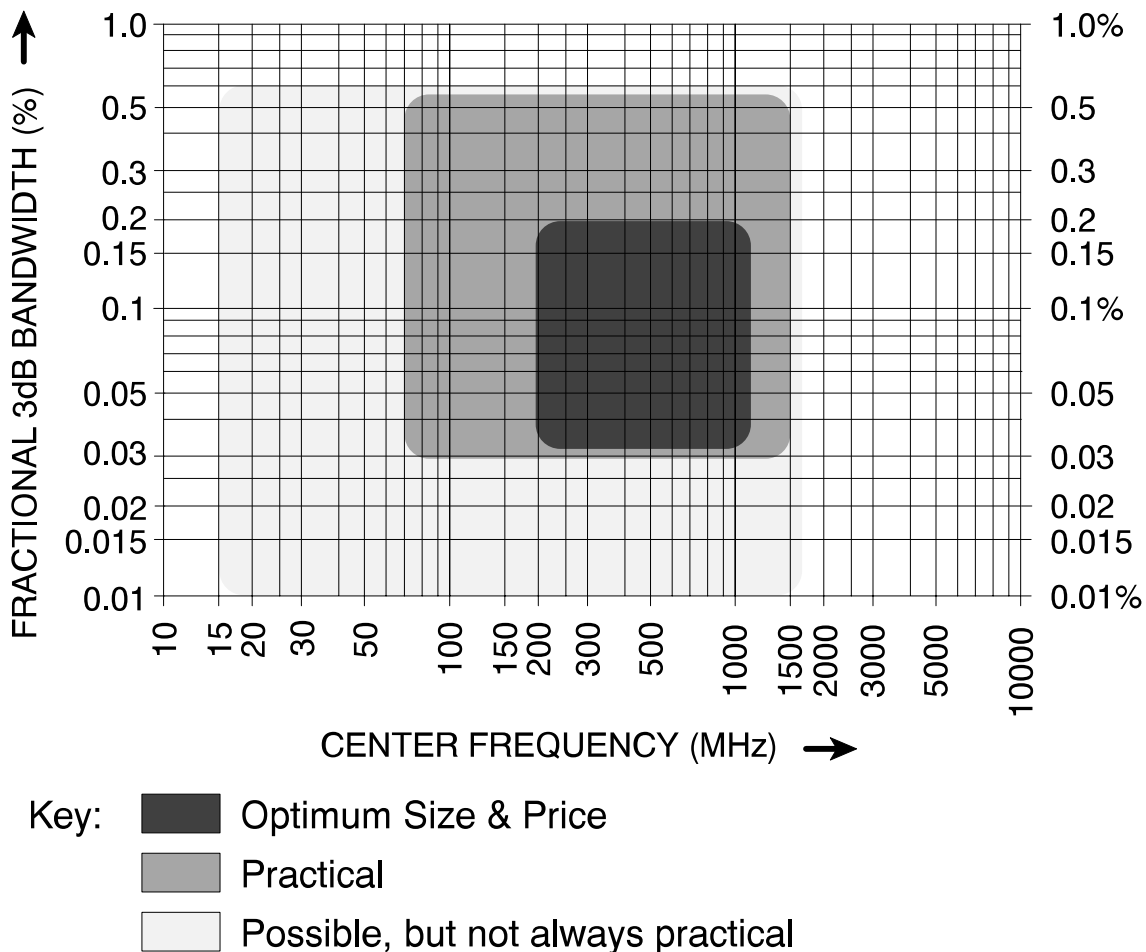

Figure No. 4: Frequency and Bandwidth Capabilities

filter technology is *not* suitable for any combination of frequency and bandwidth outside of the outer boundaries shown. Since there are many parameters that may be specified for a filter, a requirement within these regions may or may not be suitable for SAW CR technology. However, this chart is an excellent starting place in determining whether or not SAW CR technology should be considered for a given application.

Temperature is a major factor in determining the minimum practical bandwidth. The temperature characteristic of center frequency versus temperature for all SAW devices on conventional cuts of quartz is parabolic. A point of highest frequency occurs at one particular temperature defined as the “turnover” temperature, T_0 . The turnover temperature may be set in the design process to anywhere in the 0°C to 100°C range. The relationship of center frequency versus temperature may be described by either of the following two equations which are also plotted in Figure 5.

$$f_A = f_0 [1 - 0.032 (\Delta T)^2]$$

$$\Delta f / f_0 \text{ (in ppm)} = - (\Delta T / 5.6)^2$$

Where:

- T_0 = Turnover Temperature in °C
- f_0 = Turnover Frequency in Hz
- T_A = Ambient Temperature in °C
- f_A = Center Frequency (at T_A) in Hz
- ΔT = $T_A - T_0$
- Δf = $f_A - f_0$

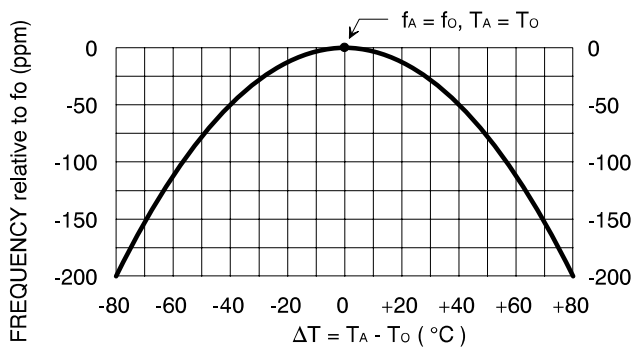

Figure No. 5: Quartz SAW CR Temperature Characteristic

The other major factor limiting minimum practical bandwidth is the production frequency tolerance (at fixed temperature). Practical center frequency tolerances range from about ±100 ppm to ±500 ppm. (This parameter affects the

unit cost and should not be specified more tightly than necessary!)

Additionally, the turnover temperature has a tolerance associated with it. Any variation of T_0 from the center of the operating temperature range worsens the overall worst case temperature variation of center frequency. Typically, the turnover temperature can be set in the design process to within about ±10°C. The production variation in T_0 is typically well within about ±5°C. However, it is usually specified at ±15°C to eliminate unnecessary testing of this parameter and to minimize unit cost. All of the above considerations determine the minimum practical bandwidth of a SAW CR filter.

As an example, consider a SAW CR filter with a center frequency of 500 MHz which will be used over an ambient temperature range of -40°C to +85°C. To minimize temperature variation, T_0 is designed to be at the center (+22.5°C) of the operating temperature range. With a T_0 tolerance of ±15°C assumed, the maximum possible $|\Delta T|$ is 77.5°C. This worst case ΔT results in a total worst case frequency variation of about 190 ppm. Once the minimum practical production variation of ±100 ppm is added, the minimum practical 3 dB bandwidth is about 390 ppm (0.039% or 195 kHz), for this particular filter. In an actual design, this minimum practical bandwidth would be added to the system signal bandwidth (plus its tolerance, if any) in order to arrive at the nominal bandwidth of the filter.

As shown above, the minimum practical bandwidth is a function of both operating temperature range and permissible unit cost which both vary with the situation. Increasing the allowed production tolerance, and hence the minimum bandwidth, would result in a more economical filter. A smaller minimum bandwidth would be possible at significantly increased unit price (tighter production tolerance) and/or by the use of an oven for temperature stabilization. If the absolute minimum bandwidth is required at the expense of cost, size, insertion loss, and power consumption, then about 0.01% (100 ppm) is possible.

The insertion loss of a SAW CR filter with impedance matching can be less than 2 dB for fractional bandwidths between 0.03% and 0.15%. (A typical maximum production specification might be about 4 or 5 dB.) Depending on size, cost, and other tolerance constraints, the required impedance matching can usually be provided either internally (inside the filter’s hermetic case) or externally (provided by the user). Typically, the required matching consists of a series inductor or series inductor and shunt capacitor per port. This is shown in Figure 6.

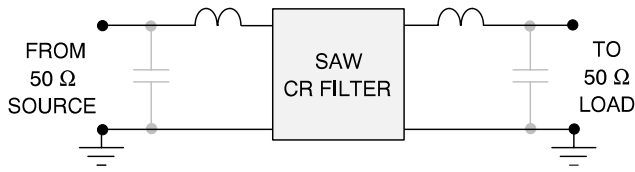

Figure No. 6: Typical SAW CR Impedance Matching Networks

In some situations, size, unit cost, or component count may be more important than insertion loss. Without any matching networks, insertion losses as low as 7 dB are possible. (A typical maximum specification might be 10 dB.) The best possible and typical insertion losses are illustrated in Figure 7 for both matched and unmatched devices. The input/output impedances of a typical unmatched SAW CR filter along with an unmatched frequency response are shown in Figure 8 as S_{11} (or S_{22}) and S_{21} (or S_{12}) in a $50\ \Omega$ system. Note that the s-parameters shown are for an unmatched device that was designed to be matched externally. Devices *designed* for unmatched applications have optimum passband ripple when terminated in the design impedance.

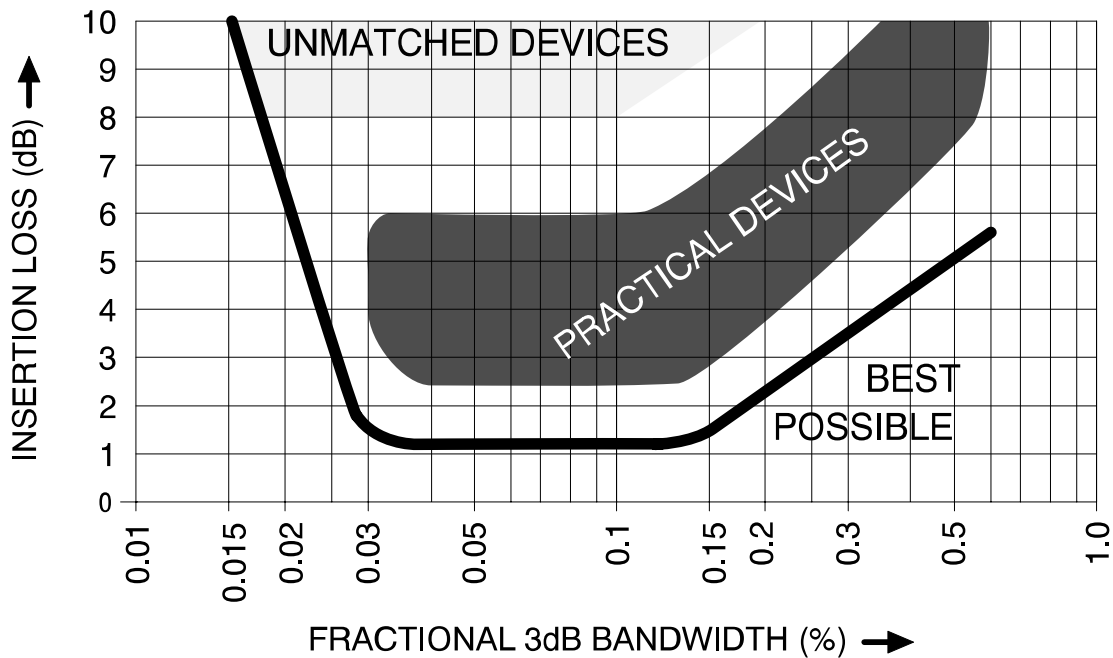

Figure No. 7: Insertion Loss Characteristics

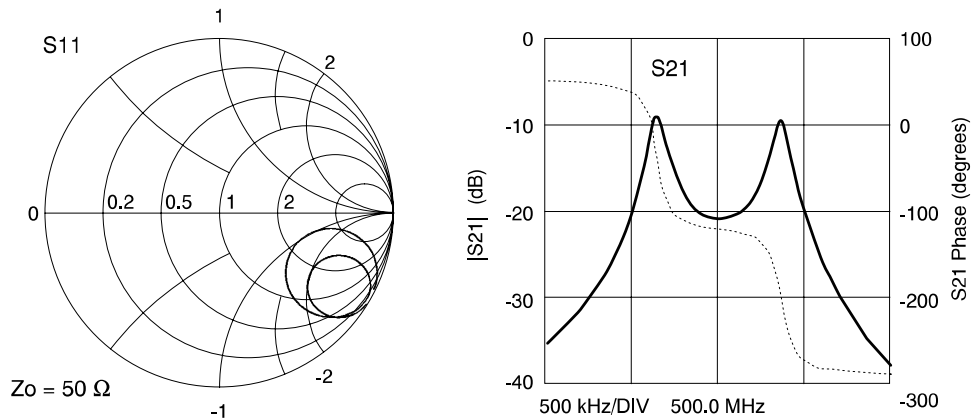

Figure No. 8: Typical S-Parameters of Unmatched SAW CR

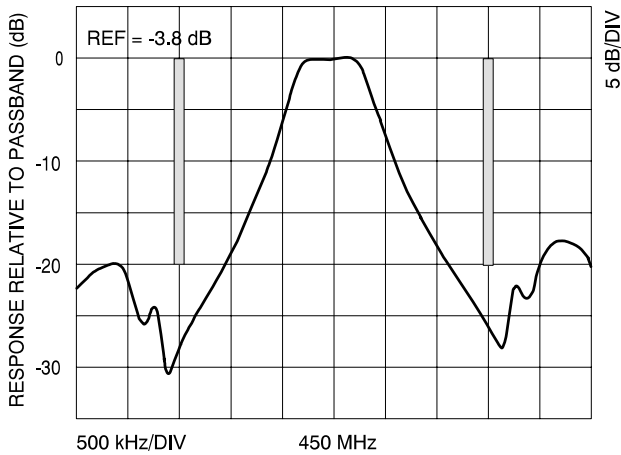

Figure 9: Typical SAW CR Frequency Response

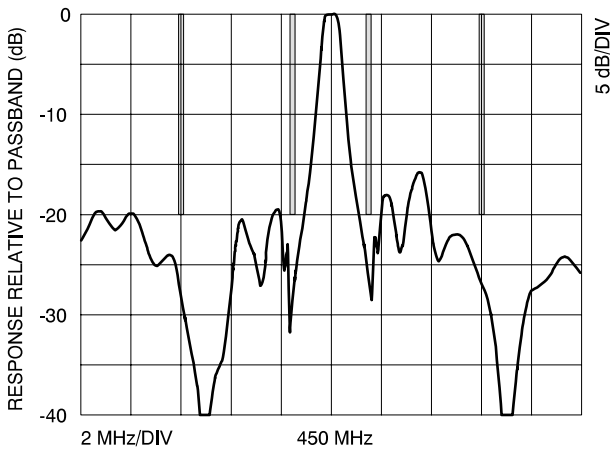

Figure 10: Typical SAW CR Response (continued)

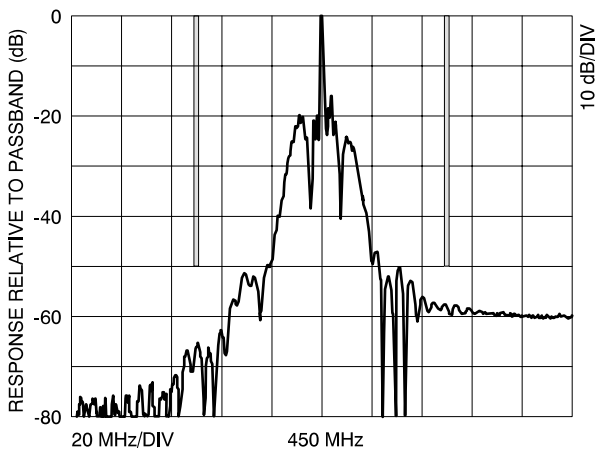

Figure 11: Typical SAW CR Response (continued)

Typical resonator unloaded Q's can range from 4000 to over 10,000. The 15/3 dB shape factor is typically about 2:1 for the main center response. Close-in spurious sidelobes can vary from 10 to 25 dBc. Ultimate rejection (typically 60 to 80 dB) is usually limited only by the parasitic electromagnetic coupling around the SAW device in the small package. One very useful characteristic of this type of filter is the complete absence of harmonic spurious responses. The frequency response of a representative device is illustrated in Figures 9 through 11. One conventional "hiccup" cavity (as shown in Figure 3) and one conjugate "hiccup" cavity are employed. This filter is representative of a SAW CR filter designed to meet specific rejection requirements (shown).

Please note that bandwidth, passband amplitude ripple, and phase linearity are highly dependent on the interaction between the SAW CR filter and the impedances presented to it by the source and load, and on the matching networks coupling to the source and load. Unlike conventional transversal SAW filters, amplitude and phase characteristics are *not* independently controllable. They are interdependent in the same manner as in an LC or other electromagnetic cavity coupled-resonator filter. (Remember that the equivalent model of Figure 1 is a good approximation near the passband.) However, this also means that conventional coupled-resonator responses (e. g., butterworth, chebyshev, gaussian, etc.) can be approximated in and near the passband of the SAW CR filter.

The positions of the nulls shown in the response can be controlled. The response of Figures 9 through 11 is a good example of selective null placement on either side of the passband. The use of two conventional "hiccup" transducers,

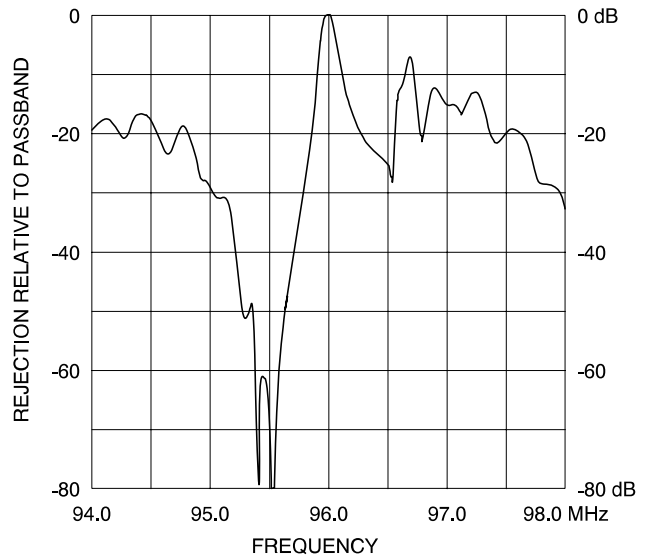

Figure 12: Response of Dual "Hiccup" SAW CR Filter

as described in the previous section, results in exceptional rejection on the low side at the expense of high-side rejection. An example of this type of response is shown in Figure 12.

SAW CR filters are nearly always supplied hermetically packaged due to the extreme sensitivity of performance to surface contamination. Cleanliness inside that hermetic package and the type of packaging affect aging performance, which is typically well under 10 ppm per year. (Current state-of-the-art aging is less than 1 ppm per year. [19]) Typically, the SAW CR filter is packaged in a metal TO-39, **Dual Inline Package (DIP)**, or flatpack. These may range in size from a $0.18'' \times 0.18'' \times 0.07''$ 8-lead flatpack at the higher frequencies to a $1.5'' \times 1'' \times 0.25''$ DIP at the lower end of the practical frequency scale. The most common and least expensive package is the TO-39 for frequencies from 200 MHz to 1650 MHz. Although numerous parameters affect the exact size of the SAW die, frequency is by far the primary factor. The lower frequencies result in larger package sizes which impact the unit cost. Some of these practical considerations are shown versus frequency in Figure 13.

What about costs? Unless an appropriate off-the-shelf design is available, **Nonrecurring Engineering Charges (NRE)** may be required. These charges start at several thousand dollars. Recurring costs can be less than \$10 in high volume for loosely specified consumer parts in TO-39 packaging with

no internal matching. Low volume, tightly specified, internally matched, SAW CR filters can cost several hundred dollars. Figure 13 illustrates *relative* recurring and nonrecurring costs as a function of frequency *with all other parameters constant*. This graph can be used to help optimize system frequencies for lowest SAW CR filter costs.

	Optimum Size & Cost	Practical	Possible	Units
Frequency	200-1200	70-1500	20-1650	MHz
Bandwidth	0.03-0.2	0.03-0.6	0.01-0.6	%
Insertion Loss	4-8	3-8	1-5	dB
Amplitude Ripple	2	0.5	0.1	dB(P-P)
Group Delay Variation	NO SPEC	150-300	100	ns(P-P)
Sidelobe Rejection	15	20	30	dB
Ultimate Rejection	50	60	80	dB

The table summarizes the *specification* capabilities of in-line SAW CR filters. (Actual performance is often better than specified.) As before, the “possible” and “optimum” ranges are completely different. The “possible” capabilities are generally only available in laboratory curiosities. The system designer should strive to use the “optimum” ranges as much as possible.

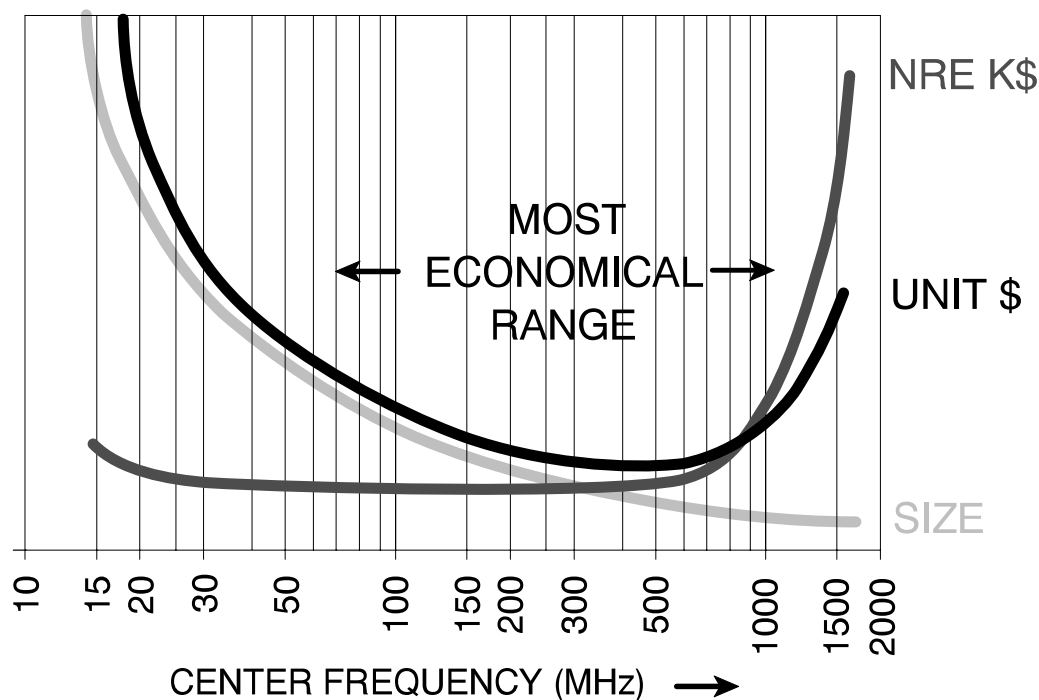

Figure 13: Practical Considerations vs. Frequency

COMPARISON WITH OTHER FILTER TECHNOLOGIES

SAW CR filter technology is complimentary to many other types of bandpass filters, including SAW transversal filters, in the frequency range of 40 MHz to 1.6 GHz. The other major types of practical bandpass filters in this frequency range include (but are not limited to) crystal, LC, helical, tubular, cavity, interdigital, combline, and dielectric-resonator types. In this section some of the key characteristics, advantages, and disadvantages of these different bandpass filter technologies are briefly reviewed. Active filters and specialized devices with limited availability are not considered here. Some examples of alternate technologies not covered here are: 1) **Thin Film Resonator (TFR)** crystal filters for monolithic applications, 2) **Bias tunable Yttrium Iron Garnet (YIG)** filters for microwave frequencies, 3) all filters below 10 MHz, and 4) all filters above 10 GHz.

A generalized map of frequency and bandwidth capabilities is shown in Figure 14 for the frequency range of 10 MHz to 10 GHz and for fractional bandwidths of 0.01% to 100%. This chart can be used as a guide in determining which bandpass filter technologies should be considered for any particular project. A filter type should be seriously considered if the frequency and bandwidth fall within the boundaries shown. Please note that typically, the optimum ranges of frequency and bandwidth for a given filter type are illustrated by the central areas of the regions shown in Figure 14. It is generally wise to assume that points near the boundaries may be possible but may not be entirely practical for every application in terms of size, cost, manufacturability, or availability. Points outside of the boundaries for a particular filter type indicate that it is probably unsuitable. Although often possible, these are likely to be expensive laboratory curiosities.

Of course, since there are many more filter parameters than frequency and bandwidth, the identification of a candidate filter type with the chart of Figure 14 is only the start of the selection process. The boundaries shown are based on reasonably practical ranges and are somewhat subjective. The actual boundaries are certainly a function of which parameters require optimization in a given application. In general, lower frequencies than shown are possible if size and cost are of no concern. Often narrower bandwidths are possible if insertion loss can be sacrificed and temperature is relatively stable. Also, it is apparent that several filter technologies are often possible for any given combination of frequency and bandwidth. More must be known about the available filter types and the intended application.

In this frequency range, bandpass filters can be divided into two broad categories: piezoelectric and electromagnetic. Following is a brief description of some of the major types in these categories. Unless noted otherwise, the piezoelectric filters are generally not tunable and the electromagnetic filters are.

Piezoelectric Bandpass Filters Above 10 MHz

Crystal filters (either discrete or monolithic) are well known and widely used. Topologies include ladder for narrower bandwidths and lattice for wider bandwidths. These devices rely on **Bulk-mode Acoustic Waves (BAW's)** that pass directly through a quartz crystal. They offer excellent Q, selectivity, ultimate rejection, the best temperature stability, and the narrowest bandwidths of all of the filter types being considered here. Key disadvantages include spurious responses, limited power handling, the generation of intermodulation products, and a lack of ruggedness in high shock and vibration environments. For very narrow bandwidths (about 0.01%), fundamental frequencies of up to 200 MHz are possible, although most practical devices are well below 100 MHz. Very narrow bandwidth overtone designs are also possible. At frequencies below 30 MHz, bandwidths as wide as 7% are possible with wideband lattice designs, but most practical devices are well below 1%. In the frequencies that overlap SAW CR filter frequencies (approximately 70 MHz to 100 MHz) the widest practical bandwidths are typically less than 0.1%. These characteristics make them ideal for many narrowband receiver applications, especially 10.7 MHz and 21.4 MHz IF filters. [20]

Ceramic filters are primarily used in receiver IF applications at 10.7 MHz and 455 kHz. This filter is possible, but not common, at frequencies higher than 10.7 MHz. Typical bandwidths range from about 1% to 3%. There is virtually no overlap with SAW CR capabilities. (This piezoelectric device should not be confused with dielectric resonator filters which are sometimes referred to as "ceramic" filters.)

SAW transversal filters include conventional high-loss (typically more than 20 dB) and newer mid and low-loss (5 to 15 dB) designs using single or multilevel metallizations. The highest center frequency practical for fundamental-mode high-loss designs is about 800 MHz with 1.5 GHz possible. For low and mid-loss designs, frequencies well over 1 GHz are practical, with maximum practical bandwidths up to about 10%. The lower limits of frequency are limited by the same size/cost constraints that affect SAW CR filters. The narrowest practical bandwidth is about 0.2% to 0.3% with 0.1% possible. For conventional high-loss designs, bandwidths up to 30% to 50% are practical. Bandwidths over 100% are possible with sacrifices in rejection

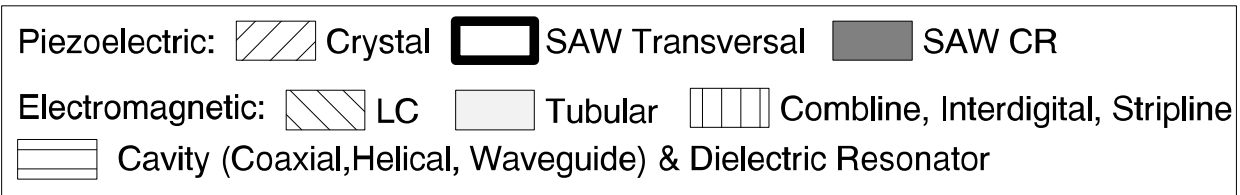
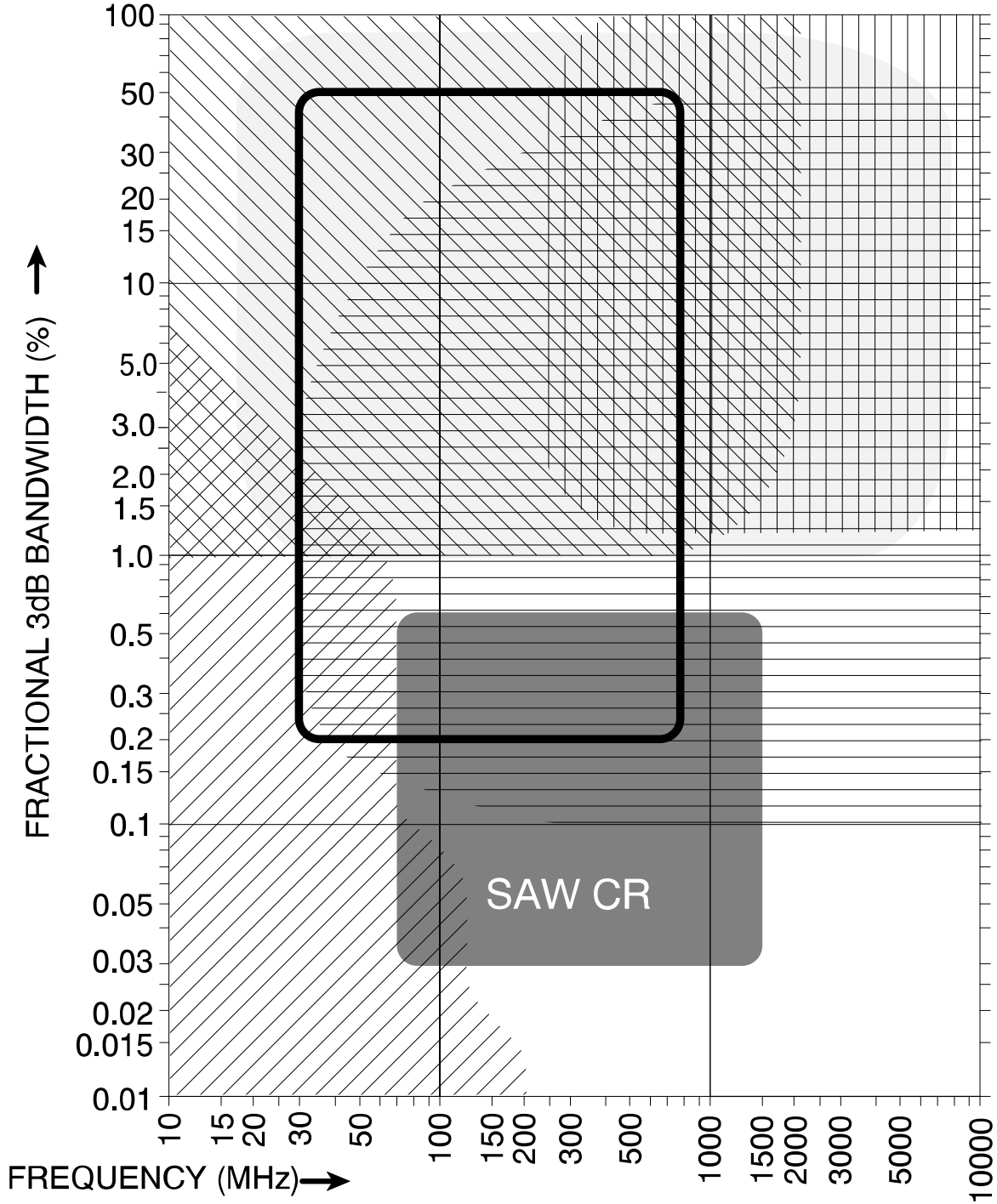

Figure 14: General Bandpass Filters — 10 MHz to 10 GHz

characteristics. Related devices (e. g., those utilizing surface skimming bulk waves, and others) are capable of fundamental mode center frequencies as high as 2.5 GHz. Also, harmonic responses have been utilized as high as 3 GHz.

A unique advantage of the transversal SAW filter is the independent control of amplitude and phase characteristics in the passband due to the time domain nature of the design. (This filter is essentially “digital” in nature.) Other advantages include excellent passband group delay and amplitude ripple characteristics, steep shape factors (typically 1.5:1), small size at higher frequencies, good temperature stability, and excellent manufacturing reproducibility. Disadvantages include substantial NRE costs for designs not available, limited power handling, odd or even harmonic spurious responses, and (for high-loss designs) triple transit spurious responses in the time domain. Absolute time delays (which can often be designed to a specific value) range from several hundred nanoseconds to several microseconds. This delay can be desirable or undesirable, depending on the application. These filters find frequent use in signal processing applications and wideband receiver IF sections.

SAW CR filter capabilities were described in previous sections. Key advantages of this type of filter include very low insertion loss, high Q, very narrow bandwidths, selective null placement, and excellent ultimate rejection with no harmonic spurious responses. Additional advantages are good temperature stability, very small size at UHF, and low unit costs at UHF. As shown in Figure 14, this filter technology has little or no competition for the higher frequencies and narrower bandwidths. Disadvantages include somewhat limited power handling, close-in sidelobe responses, and NRE charges for custom designs. The lack of tunability saves labor costs in production, but can limit flexibility. This characteristic can be an advantage or a disadvantage, depending on the application. The general advantages and disadvantages of the SAW CR filter are summarized in the following table:

Advantages	Disadvantages
Compact Size	Moderate NRE Charges
Low Unit Cost	Close-in Sidelobes
Low Insertion Loss	Limited Power Handling
Narrow BW at High Frequency	
Selective Null Placement	
Good Temperature Stability	
No Harmonics	
Only Choice for some Freq.s & BW's	

The low loss of these devices makes them suitable for many front-end applications. They are experiencing increasing application at higher IF frequencies, permitting fewer receiver

frequency conversions. Their use is also increasing in UHF frequency control applications.

Electromagnetic Filters, 10 MHz to 10 GHz

The conventional, lumped element **LC filter** has been improved considerably in the past decade by the development of smaller components with higher Q at high frequencies and by CAD techniques. This type of filter has tremendous design flexibility and practically no lower frequency limit or upper bandwidth limit. The present upper practical limit for frequency is about 2 GHz and the lower bandwidth limit is about 1%. Additional advantages include good power handling and insertion loss at the lower frequencies and small size at the higher frequencies. Custom designs are available with short lead times and little or no NRE charges. Disadvantages include poor Q at high frequencies, moderately high unit costs, and only fair temperature and vibration characteristics. This type of filter is a good general purpose choice excellent for lower frequency and wider bandwidth applications. [20-23]

Comblines filters are essentially the same as LC filters but with the inductances distributed instead of lumped. This permits higher Q (about 3500), higher frequencies, and less shock and vibration sensitivity than LC filters. Practical frequencies range from 300 MHz to well over 10 GHz. The most practical bandwidths range from 3% to 20% with 1% to 50% possible. The closest spurious response is just above four times the center frequency. Advantages include low insertion loss (typically under 1 dB), high power handling capability (up to several hundred watts), and small size at the higher frequencies. Disadvantages include fairly high recurring unit cost and large size at lower frequencies. [24, 25]

Interdigital filters are similar to combline filters, but are made entirely of distributed reactances. Frequency, Q (up to 5500), and bandwidths are all somewhat higher than combline filters, but the size is also somewhat larger. The practical limits of frequency are 500 MHz to well over 10 GHz. Bandwidths of 5% to 80% are most practical with 3.5% to 100% possible. Insertion loss, power handling, advantages, and disadvantages are very similar to those of combline filters. Additionally, size can be excessive for the narrower bandwidths as well as for the lower frequencies.

Suspended substrate stripline and/or **microstrip** bandpass filters can be implemented in a variety of ways but are usually a printed implementation of the interdigital filter described above. This type of filter is feasible down to 100 MHz, but is not usually considered practical below 1 GHz due to size. The upper frequency limit is well over 10 GHz.

Tubular filters are made of direct-coupled or capacitively-coupled resonator sections installed in a tube. Practical frequencies range from 15 MHz (with fairly large size) to about 8 GHz. Bandwidths range from 1% to 80%. Advantages include low loss, high power handling at lower frequencies, virtually no spurious responses, and little or no NRE charges for custom designs. Disadvantages include large size at lower frequencies, no method to externally tune, and high unit costs.

Cavity-resonator filters are usually implemented with **helical, coaxial, or waveguide** resonators. Waveguide filters are feasible down to 1 GHz, but with excessive size. Waveguide filters are not discussed further here since there is essentially no overlap with SAW CR technology. Coaxial and helical filters are essentially the same with $\lambda/4$ resonators in cavity enclosures. The only difference between helical and coaxial cavities is the shape of the resonator, which is compressed into a helical coil for reduced size in helical designs. Coaxial filters are available in frequencies from 30 MHz to over 10 GHz and helical filters from below 10 MHz to 2 GHz. Size is quite excessive for both of these at the lower ends of their frequency ranges. Practical helical filter bandwidths range from 0.2% to 20%. Practical coaxial filter bandwidths range from 0.2% to 3.5%. Advantages include excellent Q (up to 10,000), good selectivity, and low loss. The primary disadvantages are size and cost. (Depending on specifications and frequency, helical filters can be very economical and reasonably compact, however.)

Dielectric resonator filters, like SAW CR filters, have been developed fairly recently. They are available for center frequencies from less than 500 MHz to over 10 GHz. Practical bandwidths range from about 0.1% to over 50% with insertion losses in the range of 1 dB to 5 dB. More than two poles are available. The nearest spurious responses are beyond 1.3 times the center frequency. Power handling can be several hundred watts for the lowest frequency devices. The combination of low loss, wide bandwidth, and good power handling makes this filter ideal for many transceiver duplexer applications.

Note that at comparable frequencies, SAW CR filters are usually considerably smaller in size than any of the electromagnetic filters and are usually significantly less expensive (except for low cost helicals) in production volumes. However, all of these filters have their application niche and can be considered complimentary to one another. (i. e., No single filter type has all of the advantages that are ideal for every requirement.) The SAW CR filter is one of the newest of these filter types. Consequently, its advantages are not widely known and its niche is not fully established. As a result, many system designers are not getting the most out of their system designs. We will look at this in the next section.

APPLICATIONS

Applications of SAW CR filters fall into two major categories: frequency selection (filtering) and frequency control (oscillator stabilization). The low insertion loss of the SAW CR filter makes it an ideal filter for many receiver front end applications. The narrow bandwidth makes it suitable for many receiver IF applications with some unique benefits. And, as will be shown, its properties make it ideal for stabilization of UHF oscillators.

Receiver Front-End

The combination of small size, low unit cost, and low insertion loss can be used to advantage in receiver front-ends. An additional benefit of SAW CR filter technology in this application is the application of the selective null placement described in earlier sections. When the receiver frequency scheme and the SAW CR preselector are both designed for each other, it is often possible to place a null in the frequency response at the image frequency. Usually, this is accomplished with the dual "hiccup" design described earlier. In this SAW CR filter design, a null of 80 dB is often possible at 910 kHz below the center of the receiver passband. This provides excellent image rejection for a conventional 455 kHz IF. Frequently, a dual conversion receiver can be replaced by a single conversion design *with no sacrifice in performance*. An example of this enhancement is the guard receiver portion of the ARC-182 ECCM (Electronic Counter-Counter Measures) transceiver developed for the U. S. Navy. (See Figure 15.) The previous versions of this receiver were dual conversion. In this case, small size was the critical design parameter. SAW CR filter technology was the key to meeting that design goal.

If a SAW CR filter is chosen for a receiver front-end only because of size, cost, ultimate rejection, and loss, then the receiver designer might not know that he could get by with only a single conversion receiver. If the SAW CR filter is specified and ordered only after committing to a dual conversion receiver design, then considerable price/performance/size advantage might be left untapped! For this reason, the system designer should contact the SAW device manufacturer with details of the application very early in the system design phase of the project. Provide the SAW manufacturer with the system frequency scheme and rejection wish list. Many requests are turned down as not practical, but often that extra bit of knowledge allows the SAW CR filter designer to provide unexpected enhancements in system performance. [26-28]

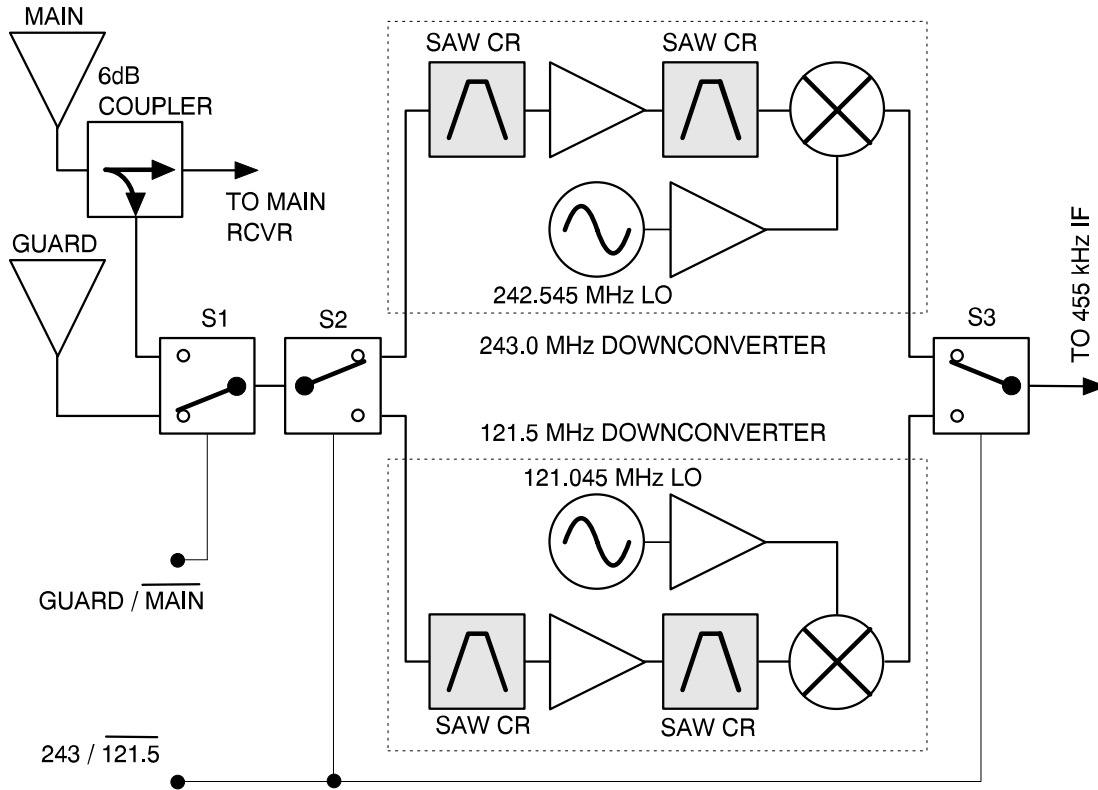

Figure 15: Guard Receiver Front-End

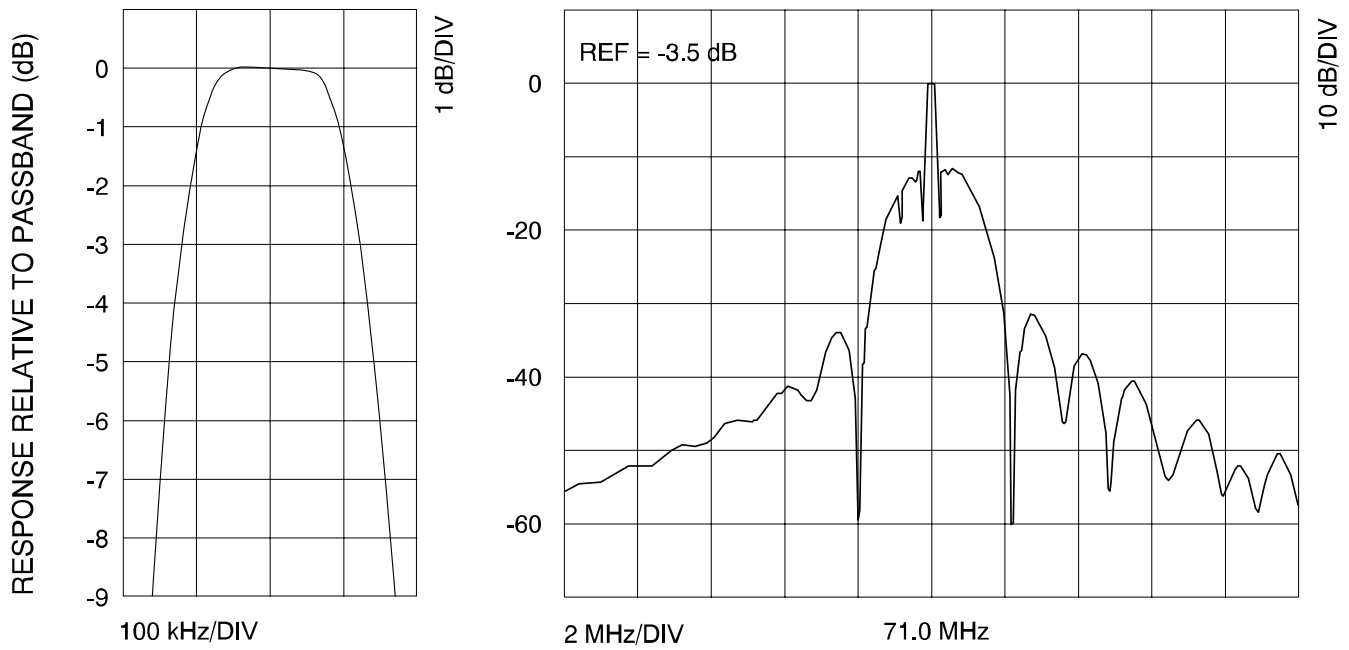

Figure 16: Digital Cellular Telephone IF Filter

Receiver IF

The SAW CR filter's small size, low unit cost, and narrow bandwidth make it an excellent candidate for many receiver IF applications. One practical application is in the handheld, cellular telephone. Potentially small size and low cost are obviously key to this size and price competitive application. SAW CR filters have been successfully designed for both conventional and the new, wider bandwidth, digital cellular telephones. Digital cellular telephones include the GSM (*Groupe Speciale Mobile*) system for the Pan-European mobile communications market. An example of a SAW CR filter designed for a digital cellular telephone IF is shown in Figure 16.

Note that the center frequency of this filter is above 70 MHz. (Some designs use IF's at frequencies well above 100 MHz.) These higher IF frequencies allow the SAW CR filter to be both reasonably small and cost effective while also moving the image frequency of the receiver farther away where the preselector can provide better image rejection. The result is both better performance and lower cost than could have otherwise been achieved. The result is state-of-the-art for this type of product.

Currently, a common mistake in the cellular telephone industry is the choice of 45 MHz for the IF. That frequency was popular in conventional cellular telephones with crystal IF filters. However, that frequency does not permit the performance, size, and cost advantages made possible with a SAW CR filter. The wider bandwidth required by digital cellular is possible, but difficult, with a crystal filter. Some digital telephone manufacturers are moving to the higher IF frequencies and using SAW CR filter technology. Some are trying to stay at 45 MHz. Guess which will have the competitive edge! Traditional approaches are not always the most risk free. The system should be designed to take advantage of the available technologies.

Fiber-Optic Clock Recovery

A unique application of SAW CR filter technology is clock recovery and data reconditioning in telecommunications fiber optic transmission networks. An example is the recovery of the 155.52 Mb/s clock in the Synchronous Optical NETWORK (SONET). (See Figure 17 for a basic block diagram.) The SAW CR filter offers one of the simplest, least expensive, and most reliable methods of extracting the clock signal. Once extracted, it is used to retime the data with significantly less jitter. The narrow bandwidth, the regenerative effect of the "ringing" acoustic cavity, and the high frequency of the SAW CR filter make it ideal for this application.

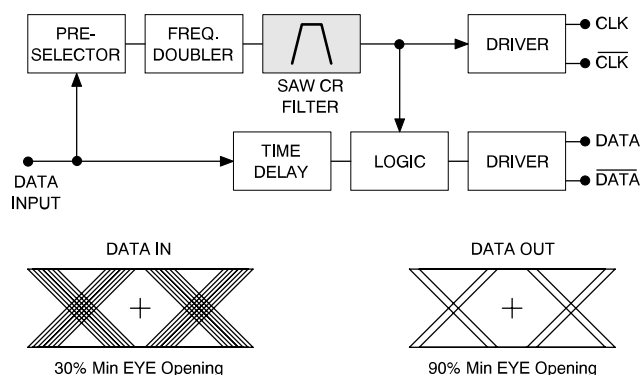

Figure 17: Fiber Optic Clock Recovery & Data Retiming

Multiplier Frequency Selection

This application uses the SAW CR as a filter, but in a novel frequency control application. Multiplied crystal oscillators are sometimes used for stable UHF frequency sources. This may be appropriate when a free running SAW oscillator does not provide sufficient stability and a Voltage Controlled SAW Oscillator (VCSO) phase locked to a stable low frequency crystal oscillator is not appropriate for several possible reasons.

In this example, the crystal oscillator frequency may be multiplied by one of many different methods. Even a step recovery diode multiplier can be used which is rich in harmonics. The absence of any harmonic responses in the SAW CR filter allows the selection of the desired harmonic. This is shown in Figure 18.

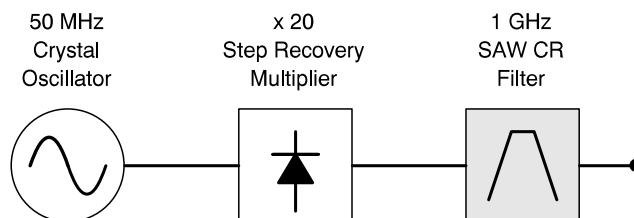

Figure 18: Multiplier Harmonic Selection

Inductorless Oscillators

The phase shift of a two-pole SAW CR filter between the 3 dB points is 180°. This type of phase characteristic provides a very favorable condition for designing a UHF oscillator without impedance matching or inductors. [30]

One application of this technique is in the high performance oscillator that cannot have coils because of size or vibration requirements. Another is in low cost, high volume devices where it is desirable to have only a SAW device and an IC to minimize parts count and eliminate production adjustments. An example of such a low cost application is the Microtransmitter manufactured by RF Monolithics. This device is available for frequencies between 200 MHz and 450 MHz and fits in a TO-39 package. It is sold for low cost, high volume consumer remote control applications. This type of device is made possible by the use of SAW CR filter technology. [31] The block diagram is shown in Figure 19.

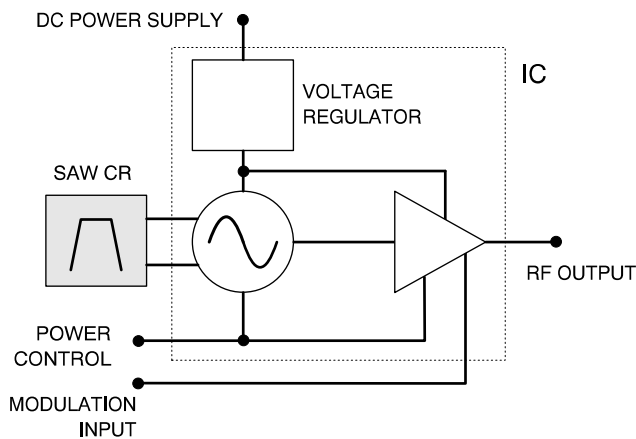

Figure 19: The Microtransmitter

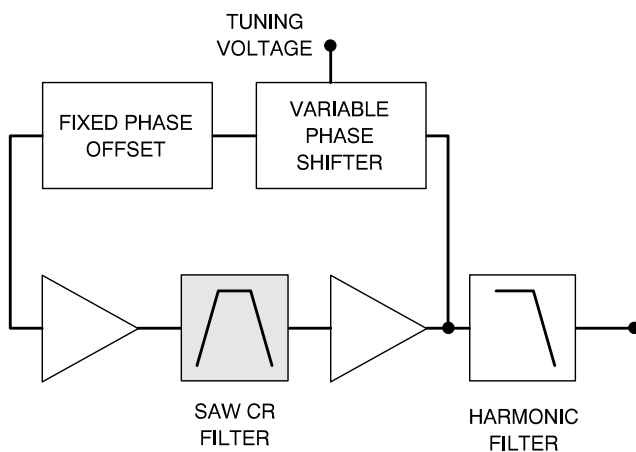

Figure 20: A VCSO Stabilized with a SAW CR

VCSO's

A VCSO is typically phase locked to a stable reference crystal oscillator. The VCSO must be able to tune over a range sufficient to compensate for all frequency variations in the VCSO, which are usually dominated by temperature variations. This tuning range is directly influenced by the bandwidth of the SAW device in the VCSO. Therefore, it is desirable to have a SAW device with a fairly wide bandwidth. Yet the wider the bandwidth, the worse the SSB (Single SideBand) phase noise. Consequently, it is necessary to carefully balance the bandwidth of the SAW device for optimum VCSO performance. The SAW CR filter permits excellent control of its bandwidth and is therefore an ideal device for VCSO frequency stabilization. [32] A block diagram of such a VCSO is shown in Figure 20. (High performance VCSO designs with one-pole SAW resonators are also possible, but with greater complexity. [33])

This section has identified only some of the principal applications of SAW CR filters. As this new technology becomes more widely used, it is expected that many more applications will be discovered that offer unique advantages over prior techniques.

SUMMARY

The SAW CR filter was shown to be a valuable addition to the many possible choices of bandpass filtering technologies available in the VHF and UHF frequency ranges. The basic concepts of this filter technology were reviewed specifically to provide background to the RF circuit and system design engineer. Performance capabilities and limitations were summarized, including practical information about cost optimization. SAW CR filter technology was compared with the major types of passive bandpass filter technologies available for the same frequency ranges. Practical reference material was developed as an aid in choosing the optimum bandpass filter technology for any given application. Finally, application examples of SAW CR filters were given. The proper choice of filter technology *at the system design phase* was emphasized in order to optimize performance and minimize system development time and cost, and recurring system costs.

REFERENCES

1. E. A. Ash, "Surface Wave Grating Reflectors and Resonators," *Proceedings IEEE International Microwave Symposium*, May, 1970, pp 385-386.
2. G. L. Mathaei, B. P. O'Shaughnessy, F. Barman, "Relations for Analysis and Design of Surface Wave Resonators," *IEEE Transactions Sonics & Ultrasonics*, SU-23, March 1976, pp 99-107.
3. H. A. Haus, R. V. Schmidt, "Transmission Response of Cascaded Gratings," *IEEE Transactions Sonics & Ultrasonics*, SU-24, March 1977, pp 94-101.
4. P. S. Cross, R. V. Schmidt, "Coupled Surface-Acoustic-Wave Resonators," *The Bell System Technical Journal*, Vol. 56, No. 8, October 1977, pp 1447-1482.
5. W. J. Tanski, "Multipole SAW Resonator Filters: Elements of Design and Fabrication," *Proceedings IEEE Ultrasonics Symposium*, 1981, pp 100-104.
6. T. F. O'Shea, "SAW Resonator Filters with Optimized Transducer Rejection," *Proceedings IEEE Ultrasonics Symposium*, 1981, pp 105-110.
7. P. C. Meyer, D. Gunes, "Design and Fabrication of SAW Multipole Filters," *Proceedings IEEE Ultrasonics Symposium*, 1983, pp 66-71.
8. M. B. King, L. W. Heep, J. C. Andle, "1500 MHz Coupled Resonator Filter," *Proceedings IEEE Ultrasonics Symposium*, 1987, pp 127-130.
9. W. R. Shreve, "Surface-Wave Two-Port Resonator Equivalent Circuit," *Proceedings IEEE Ultrasonics Symposium*, 1975, pp 295-298.
10. M. Tanaka, T. Morita, K. Ono, Y. Nakazawa, "Narrow Bandpass Filter Using Double-Mode SAW Resonators on Quartz," *Proceedings IEEE Frequency Control Symposium*, 1984, pp 286-293.
11. Y. Ebata, H. Satoh, "Current Applications and Future Trends for SAW in Asia," *Proceedings IEEE Ultrasonics Symposium*, 1988, pp 195-202.
12. P. V. Wright, "Resonator," U. S. Patent No. 4,616,197, Oct. 1986.
13. J. C. Andle, "Doubly Rotated Orientations of Cut Angles for Quartz Crystal for Novel Surface Acoustic Wave Devices," U. S. Patent No. 4,670,680, June 1987.
14. P. V. Wright, "Resonator Structure," U. S. Patent No. 4,731,595, March 1988.
15. P. V. Wright, "Low-cost High-Performance Resonator and Coupled-Resonator Design: NSPUDT and Other Innovative Structures," *Proceedings 43rd Annual Symposium on Frequency Control*, 1989, pp 574-587.
16. P. V. Wright, "Method of Making a Single Phase Unidirectional Surface Acoustic Wave Transducer," U. S. Patent No. 4,910,839, March 1990.
17. P. V. Wright, "A New Generalized Modeling of SAW Transducers and Gratings," *43rd Annual Symposium on Frequency Control*, 1989, pp 596-605.
18. P. V. Wright, "Analysis and Design of Low-Loss SAW Devices with Internal Reflections Using Coupling-of-Modes Theory," *Proceedings IEEE Ultrasonics Symposium*, 1989, pp 141-152.
19. T. E. Parker & G. K. Montress, "Frequency Stability of High Performance SAW Oscillators," *Proceedings IEEE Ultrasonics Symposium*, 1989, pp 37-45.
20. M. D. Howard and R. C. Smith, "Quartz Crystal Filters: A Review of Current Issues," *Proceedings RF Technology Expo 90*, March 1990, pp 275-288.
21. E. Christian, *LC Filters: Design, Testing, & Manufacturing*, John Wiley & Sons, New York, 1983.
22. B. G. Malcom, "The Current State of the Art of Miniature L/C Filters," *Proceedings IEEE Ultrasonics Symposium*, 1985, pp 38-42.
23. R. Levy, "Design Considerations for Lumped-Element Microwave Filters," *Microwave Journal*, February, 1988, pp 183-192.
24. A. I. Zverev, *Handbook of Filter Synthesis*, John Wiley & Sons, New York, 1967.
25. G. L. Matthaei, L. Young, E. M. T. Jones, *Microwave Filters, Impedance-Matching Networks, and Coupling Structures*, Artech House, Dedham, MA, 1980.
26. D. Ash, "Optimal Application of SAW Devices in Spread Spectrum and Other RF Systems," *Proceedings IEEE Ultrasonics Symposium*, 1989, pp 265-274.
27. J. Iseli, "Receiver Design -- Simplified," *Proceedings RF Technology Expo East*, 1988, pp 17-22.
28. P. Zibis, "UHF Low Loss SAW Filters for Front End Applications," *Proceedings IEEE Ultrasonics Symposium*, 1986, pp 293-297.
29. G. Riha, "Saw Devices for Communications Systems," *Proceedings IEEE Ultrasonics Symposium*, 1989, pp 241-250.
30. D. Ash, "Coupled Resonator Phase Shift Oscillator," U. S. Patent No. 4,760,352, June 1988.
31. J. M. Robinson, "A SAW Stabilized Monolithic Pulse Amplitude Modulated Microtransmitter," *IEEE Transactions on Consumer Electronics*, August 1987.
32. J. M. Robinson, "SAW Coupled Resonator Oscillator Technology," *Proceedings IEEE Ultrasonics Symposium*, 1989, pp 47-51.
33. M. M. Driscoll, "Linear Frequency Tuning of SAW Resonators," *Proceedings IEEE Ultrasonics Symposium*, 1989, pp 191-194.

This application note is an adaptation of a paper presented at RF Expo East on November 13, 1990 in Orlando, Florida.



RF Monolithics, Inc.

4441 Sigma Road

Dallas, Texas 75244 USA

Telephone: (214) 233- 2903

FAX: (214) 387-8148

© Copyright 1990, RF Monolithics, Inc.

All Rights Reserved

AN23-A-16-120690AC